

Economics and Carbon Offset Potential of Biomass Fuels

Final Report 1999

P. Girouard, C. Zan, B. Mehdi, R. Samson

Resource Efficient Agricultural Production (REAP) – Canada
Box 125, Ste-Anne-de-Bellevue, Quebec, H9X 3V9

Project Partner:

Dr. J. Fyles: Department of Natural Resource Sciences, Macdonald Campus of
McGill University, Ste-Anne-de-Bellevue, Quebec

This work was awarded through Environment Canada's Environmental Innovation Program and
Supported by CANMET/NRCan

This work was funded by the Federal Panel on Energy Research and Development (PERD)
Contract 23341-6-2010/00 1/SQ

July 1999

ABSTRACT

The broad objective of this 3-year study was to develop economic, energy, and carbon emission budgets associated with the cultivation of switchgrass and short-rotation forestry (SRF) willow plantations grown as part of a CO₂ offset strategy. Field experiments and computer models were used to meet this objective. The study showed that with proper management and soil conditions, the production of SRF willow and switchgrass can result in soil organic carbon sequestration under eastern Canadian conditions. The resulting biomass feedstock which are produced, are estimated to be at least carbon neutral with largely positive energy balances.

EXECUTIVE SUMMARY

The urgency of Canada, as well as other countries, to find viable alternatives to curbing greenhouse gas (GHG) emissions is of utmost importance. The potential of perennial crops to sequester carbon may be of significant importance, and warrants further research, especially in light of the Kyoto Protocol. By growing perennial biomass crops, carbon is stored in the above- and belowground plant material, and potentially in the soil, for a temporary period of time. In addition, end use applications of biomass crops can further reduce GHG emissions by substituting fossil fuels used in home heating appliances, or in automobiles with biofuels.

This study examines the potential of short rotation forestry (SRF) willow (*Salix alba x glatfelteri* L.) and switchgrass (*Panicum virgatum* L.) to store carbon in their above and belowground biomass, and in the soil. The study also develops economic, energy and carbon emission budgets associated with the cultivation of these two promising perennial crops.

The field study was conducted at two sites of inherently different fertility. The Ecomuseum site was more fertile at the onset of the experiment, compared with the Seedfarm site. Plantations of switchgrass and SRF willow were established at both sites in 1993, to assess productivity and economic feasibility between systems. In 1996, the study was expanded to include assessments of soil organic carbon concentrations and carbon levels in above- and belowground plant material. Corn (*Zea mays* L.) was introduced in 1996 as a comparison crop for switchgrass and SR willow. Mean harvestable biomass yields were similar between the perennial biomass crops and averaged 12.3 odMg/ha for switchgrass and 12.0 odMg/ha for SRF willow over the 3 years. Corn yields were approximately 7.3 odMg/ha on both sites. This study provided a first time assessment of the potential amounts of soil organic carbon sequestered in the biomass and soil under SRF willows and under switchgrass, in eastern Canada.

In order to investigate harvestable biomass, the average annual field productivity (Chapter 2) was evaluated on switchgrass (Cave-in-Rock), willow shoots (*Salix alba x glatfelteri*), and grain corn for both sites. The mean yields, from 1996 to 1998, on the two plantation sites of switchgrass and SRF willows were very similar, at 12.0 and 12.3 odMg/ha, respectively. Both of these biomass crops can obtain productive yields once fully established.

Switchgrass had consistent yields across the plantations, in contrast to the SRF willow, where the most variable results were found at the Seedfarm. The switchgrass yields were almost identical at both sites (12.2 and 12.5 odMg/ha, at the Seedfarm and the Ecomuseum, respectively), while overall, the SRF willow at the Seedfarm had 21% higher yields than at the Ecomuseum.

The corn plots had productive grain yields in 1996 and 1998. Nevertheless, the average grain yield of the corn was approximately one third lower than that of the two perennial crops, with two-year average grain yields for both sites of 8.2 odMg/ha.

Average 1996-98 Yields of Short Rotation Forestry Willow, Switchgrass and Grain Corn at the Plantation Sites in Ste-Anne-de-Bellevue, Quebec				
	Variety	Seedfarm	Ecomuseum	Average
		odMg/ha		
Short Rotation Forestry	<i>Salix alba x glatfelteri</i>	13.1	10.8	12.0
Switchgrass	Cave-In-Rock	12.2	12.5	12.3
Corn*	Grain only	8.2	8.2	8.2

*Corn yield is an average of 1996 and 1998

The total aboveground biomass production (including litter and weeds) for all plots of switchgrass, SRF willows and corn was also measured on the Chicot fine sandy loam (Chapter 3), to provide a more detailed analysis of carbon storage in the systems. Total productivity varies between species and years, but were in a similar overall annual range. In 1996, total annual aboveground biomass was estimated at 15.6, 13.5 and 16.2 odMg/ha, for switchgrass, SRF willow and corn, respectively. In 1997, total annual aboveground biomass accumulations for switchgrass, SRF willow and corn, were 16.6, 19.0, and 13.0 odMg/ha, respectively. In 1998, the yields (excluding litter and weeds) averaged 12.8, 18.2, and 19.8 odMg/ha for switchgrass, SRF willow and corn, respectively. Since willow is harvested on a four year harvest cycle, the potential for aboveground sequestration of carbon is significantly greater than the annual harvest of switchgrass and corn.

In terms of belowground biomass production in 1996, switchgrass and SRF willows were more productive than corn, with an average yield of 7.2 and 9.0 odMg/ha, versus 1.6 odMg/ha for corn.

In 1996, SRF willow was found to have an average aboveground C content of 46%, switchgrass had 45%, and corn also contained 45% carbon. The belowground C contents (including the root crowns for willow and corn) averaged 42%, 44%, 36% for SRF willow, switchgrass and corn, respectively.

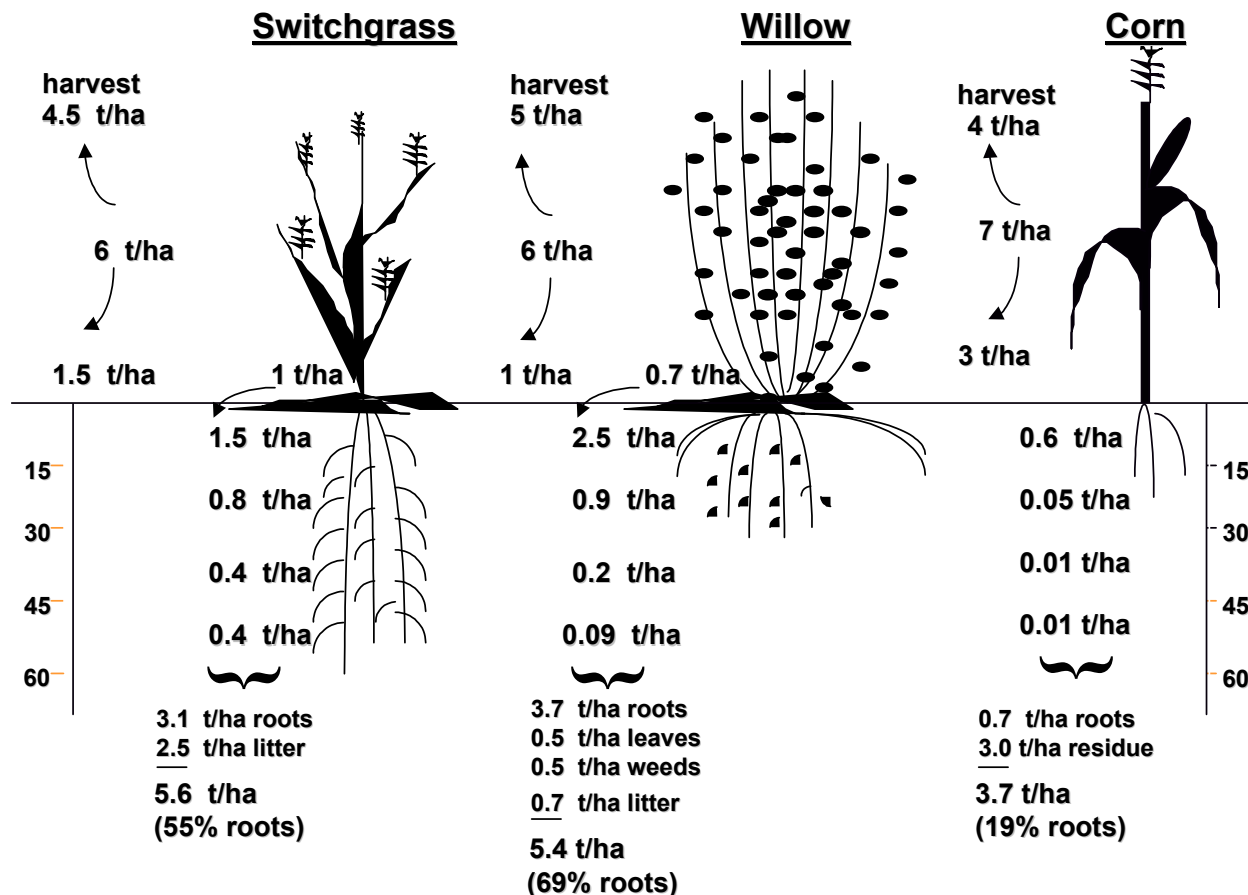

Source: Zan (1998)
 Mean carbon partitioning in switchgrass, willow, and corn at the Seedfarm and Ecomuseum sites in 1996.

The total average soil organic carbon storage, in 1996, from 0-60 cm under SRF willow, switchgrass and corn systems was 122 t/ha, 106 t/ha, and 106 t/ha, respectively, 4 years after the establishment of the perennial crops, and one season after the establishment of the annual crop (corn). In 1996, results indicated SRF willows to sequester soil organic carbon (5.3 t/ha/yr) at one of the sites (Ecomuseum) compared with switchgrass. Willow and switchgrass also sequestered soil organic carbon, compared with corn (9.0 and 3.8 t/ha/yr, respectively). On the second site (Seedfarm), no difference in soil carbon levels was measured between the SRF willow and switchgrass cropping systems.

A second soil organic matter sampling was conducted in the fall of 1998, to obtain soil organic carbon values 6 years after plantation establishment. There was no significant soil organic carbon difference between the cropping systems at the Seedfarm, nor at the Ecomuseum. However, the total average soil organic carbon storage under SRF willow was 94 t/ha, which was significantly greater than switchgrass and corn, which stored 84 t/ha and 83 t/ha, respectively.

The soil organic carbon levels decreased from 1996 to 1998, at an average rate of 11.3 t/ha/yr in the corn plots, 11.3 t/ha/yr in the switchgrass plots, and 13.9 t/ha/yr in the SRF willow plots. Most of this carbon loss took place in the 0-30 cm depth, where the losses ranged from 16 % to 31% in the treatments, from 1996 to 1998. However, when comparing 1998 SRF willow and switchgrass systems with 1998 corn systems, SRF willows at the Ecomuseum was found to store 2.4 t/ha/yr, and switchgrass 1.2 t/ha/yr, compared with corn. At the Seedfarm, willows stored 0.5 t/ha/yr, whereas switchgrass lost 1.3 t/ha/yr, compared with corn.

Mean 1996 and 1998 soil organic carbon from 0-60 cm in each cropping system			
Site	Crop	1996 [†]	1998
		Organic Carbon (t/ha)	
Seedfarm	SRF Willow	103	88 (-8)
	Switchgrass	93	77 (-8)
	Corn	108	85 (-12)
	Mean	101 b	83 b (-9)
Ecomuseum	SRF Willow	137	98 (-20)
	Switchgrass	119	90 (-14)
	Corn	105	83 (-11)
	Mean	121 a	91 a (-15)

Means with different letters, within a column, are significantly different at the 0.05 level according to the SNK test.

[†] 1996 values transformed with the regression equation $1998 = -0.086 \cdot [1996 \text{ data}] (r^2=0.99)$, to be able to compare with 1998 values

() Values in brackets represent the amount of annual incremental organic C increase (t/ha/yr) since 1996

Therefore, it appears that on a more nutrient enriched site (Ecomuseum), willow and switchgrass will sequester soil organic carbon, compared to corn. However, soil carbon levels may decrease at a given time, but for what length is unknown.

By using the 1998 data and comparing the perennial systems with the corn system, and averaging the values for both sites, switchgrass was calculated to decrease soil organic carbon

levels, at 0-60 cm, by approximately 0.06 t/ha/yr, and SRF willow increased organic carbon, at 0-60 cm, by 1.45 t/ha/yr. In years to come, these figures may be expected to change, as many studies point to perennial cropping systems sequestering less soil carbon (even losing soil carbon) during the first years of establishment, compared with subsequent years.

With the above data, economic, energy and carbon budgets were developed (Chapter 4) for SRF willow and switchgrass cropping practices. It was estimated that soil organic carbon accumulation rates of 104 kg C/ha/yr and 121-144 kg C/ha/yr, for SRF willows and switchgrass, respectively, would be sufficient to offset any carbon emitted during the combustion of fossil fuels used to grow and transport these crops. At higher rates of soil organic carbon accumulations, the crops acted as carbon sinks. With proper site selection and cropping practices, the latter possibility is attainable. When no soil carbon was sequestered by the cropping systems, fossil fuel carbon emissions were computed to be approximately one-twentieth of those of liquid fuel combustion, such as diesel.

Assuming a soil organic carbon accumulation rate of 500 kg C/ha/yr for both SRF willows and switchgrass, along with the carbon being sequestered by switchgrass and SRF willow plant material, simulations were performed. The base case simulations indicated SRF willows to be, overall, more efficient in carbon sequestering than switchgrass.

The energy budget developed during this study also indicated SRF willows to be able to produce more energy per unit of fossil fuel input (output:input ratio of nearly 30) compared with switchgrass (output:input ratio of approximately 20). However, from an economic standpoint, switchgrass was estimated to be less expensive to grow.

The results generated in this study suggest that the production of switchgrass and SRF willows should be carbon neutral, with a possibility for these crops to act as carbon sinks under proper fertility management, compared with corn.

This study cautions that when growing short rotation forestry species and perennial grasses for biomass, while obtaining high yields is of primary concern, care must be taken to maintain soil fertility, lest the loss of soil carbon. The study also indicates that soil organic carbon accumulation is dependent on a number of variables, as well as interactions, such as the annual amount of biomass returned to the soil, as well as the amount of nutrients returned to the soil. It

appears that soil carbon accumulation is furthermore dependent on time related factors. The longer the rotations, the better the chances of increasing the soil organic carbon pool.

Acknowledgments

The performance and completion of this project required the advice and cooperation of several people, especially given the complexity of the issue investigated. To all of those who have contributed to the project, the authors wish to express their gratitude and thanks.

The authors would also like to thank Dr. James Fyles for his guidance and support he provided to the project. Thank you to Christel Monod for helping in the final stages of the project, and the many field assistants who worked diligently to collect the field data.

The authors would like to thank Joe Robert and Bill Cruickshank of Natural Resources Canada for supporting this work. Their vision and funding over the years have permitted the development of a wealth of information dedicated to energy crop production, bringing the project one step closer to commercialization.

Table of Contents

Abstract	i
Executive Summary	ii
Acknowledgements	viii
List of Tables	xii
List of Figures	xvi
List of Symbols	xviii
Chapter 1. <u>Introduction</u>	1
1.1. Objectives	2
1.2. Scope	2
Chapter 2. <u>Field Productivity Assessments of Bioenergy Feedstocks</u>	4
2.1. Site Background and Description	4
2.2. Cropping Regime	8
2.2.1. SRF Willows	8
2.2.2. Switchgrass	8
2.2.3. Corn	9
2.3. Growing Conditions	9
2.4. Harvestable Biomass Yields	12
2.4.1. SRF Willows	12
2.4.2. Switchgrass	14
2.4.3. Corn	15
2.4.4. Comparison between Willow, Switchgrass, and Corn	16
2.5. Conclusions	17
Chapter 3. <u>Carbon Storage Study</u>	18
3.1. Methodology	19
3.1.1. Sampling, Site Description, and History	19
3.1.2. Modified Mebius Procedure to Determine Carbon Concentration in 1996	22
3.1.3. LECO Combustion Process to Determine Carbon Concentration in 1998	22
3.1.4. Calculations of Soil Profile Carbon on a Constant Mass Basis	22
3.1.5. Statistical Analyses	22

3.2.	Results	24
3.2.1.	Aboveground Plant Yield and Carbon Content	24
3.2.1.1.	Switchgrass	24
3.2.1.2.	Willow	25
3.2.1.3.	Corn	26
3.2.1.4.	Comparing the Ecosystems	28
3.2.1.4.1.	Biomass Yields	28
3.2.1.4.2.	Carbon Concentrations	30
3.2.2.	Belowground Plant Yield and Carbon Content	32
3.2.2.1.	Switchgrass	32
3.2.2.2.	Willow	33
3.2.2.3.	Corn	33
3.2.2.4.	Abandoned Field and Forest	34
3.2.2.5.	Comparing the Ecosystems	35
3.2.2.5.1.	Root Biomass	35
3.2.2.5.2.	Root Carbon Sequestered	37
3.2.3.	Soil Carbon	40
3.2.3.1.	Switchgrass	40
3.2.3.2.	Willow	41
3.2.3.3.	Corn	42
3.2.3.4.	Abandoned Field and Forest	43
3.2.3.5.	Comparing the Ecosystems	44
3.2.3.6.	Total Yield and Carbon in 1996	49
3.3.	Discussion	51
3.3.1.	Plant Carbon	51
3.3.2.	Soil Organic Carbon in 1996	53
3.3.2.1.	1996 Accumulation Rates	56
3.3.3.	Soil Organic Carbon in 1998	56
3.3.3.1.	1998 Accumulation Rates	59
3.4.	General Conclusion	60
Chapter 4.	<u>Economic, Energy, and Carbon Budgeting</u>	62
4.1.	Methodology	62
4.1.1.	SRF Willows	62
4.1.1.1.	Economics	62
4.1.1.2.	Energy Budgeting	65
4.1.1.3.	Carbon Emissions	66

4.1.2.	Switchgrass	69
4.1.2.1.	Economics	69
4.1.2.2.	Energy Budgeting	71
4.1.2.3.	Carbon Emissions	71
4.2.	Results	71
4.2.1.	SRF Willows	71
4.2.1.1.	Economics	71
4.2.1.2.	Energy Budget	72
4.2.1.3.	Carbon Analysis	73
4.2.2.	Switchgrass	75
4.2.2.1.	Economics	75
4.2.2.2.	Energy Budget	75
4.2.2.3.	Carbon Analysis	77
4.3.	Discussion	79
Chapter 5. <u>Summary and Conclusions</u>		83
5.1.	Summary	83
5.2.	General Conclusions	84
5.3.	Directions for Further Research	86
Bibliography		88
Appendices		
Appendix 1: Cropping Practices for SRF Willows, Switchgrass, and Corn		
Appendix 2: Literature Review for Carbon Storage Study		
Appendix 3: Additional Tables for Chapter 4		
Appendix 4: Model Simulation Results for SRF Willow		
Appendix 5: Model Simulation Results for Switchgrass – Spring		
Appendix 6: Model Simulation Results for Switchgrass – Fall		

List of Tables

Chapter 2: Field Productivity Assessments of Bioenergy Feedstocks

Table 2.1: Total monthly precipitation (mm) from 1993-1998 from Montreal/Dorval International Airport (Environment Canada)	10
Table 2.2: Mean monthly temperature (°C) from 1993-1998 from Montreal/Dorval International Airport (Environment Canada)	11
Table 2.3: Cumulative Total Corn Heat Units at selected dates from 1993-1998 from Les Cedres Agriculture Canada Meteorological Station	12
Table 2.4: Short Rotation Forestry Harvestable Annual Yield Increments (odMg/ha) from plantation sites in Ste. Anne de Bellevue, Quebec (1994-98)	13
Table 2.5: Fall Switchgrass Yields from the Plantation Sites in Ste. Anne de Bellevue, Quebec (1994-98)	15
Table 2.6: Corn Grain Yields from plantations sites in Ste. Anne de Bellevue, QC, 1996-1998	16
Table 2.7: Average 1996 - 1998 Yields of Short Rotation Forestry Willow, Switchgrass and Grain Corn at the Plantation Sites in Ste. Anne de Bellevue, Quebec	17

Chapter 3: Carbon Storage Study

Table 3.1: Switchgrass aboveground biomass (od kg/ha) and carbon content (kg/ha) for 1996 to 1998 at the Seedfarm (SF) and Ecomuseum (ECO) sites	24
Table 3.2: Willow aboveground biomass (od kg/ha) and carbon content (kg/ha) for 1996 to 1998 at the Seedfarm (SF) and Ecomuseum (ECO) sites.	26
Table 3.3: Corn aboveground biomass (od kg/ha) and Carbon content (kg/ha) for 1996 to 1998 at the Seedfarm (SF) and Ecomuseum (ECO) sites	27
Table 3.4: Average Carbon content (%) in Aboveground Biomass (Seedfarm and Ecomuseum sites - 1996)	32
Table 3.5: Switchgrass root production and Carbon sequestered at the Seedfarm (SF) and Ecomuseum (ECO) sites, at the end of the 1996 growing season.	32
Table 3.6: Willow root production and Carbon sequestered at the Seedfarm (SF) and Ecomuseum (ECO) sites, at the end of the 1996 growing season.	33

Table 3.7: Corn root production and Carbon sequestered at the Seedfarm (SF) and Ecomuseum (ECO) sites, at the end of the 1996 growing season.	34
Table 3.8: Average carbon content (%) of roots at 4 depth intervals (Seedfarm and Ecomuseum sites - 1996)	40
Table 3.9: Soil organic carbon levels measured in switchgrass plots at the Seedfarm (SF) and Ecomuseum (ECO) sites in October 1996	41
Table 3.10: Soil organic carbon levels measured in switchgrass plots at the Seedfarm (SF) and Ecomuseum (ECO) sites in October 1998	41
Table 3.11: Soil organic carbon levels measured in SRF Willow plots at the Seedfarm (SF) and Ecomuseum (ECO) sites in October 1996	42
Table 3.12: Soil organic carbon levels measured in SRF Willow plots at the Seedfarm (SF) and Ecomuseum (ECO) sites in October 1998	42
Table 3.13: Soil carbon levels measured in corn plots at the Seedfarm (SF) and Ecomuseum (ECO) sites in October 1996	43
Table 3.14: Soil carbon levels measured in corn plots at the Seedfarm (SF) and Ecomuseum (ECO) sites in October 1998	43
Table 3.15: 1996 soil organic carbon levels in four soil layers, for all cropping systems	44
Table 3.16: 1998 soil organic carbon levels in four soil layers, for all cropping systems	46
Table 3.17: Mean 1996 and 1998 soil organic carbon from 0-60 cm in each cropping system	48

Chapter 4: Economic, Energy, and Carbon Budgeting

Table 4.1: Nitrogen, Phosphorous, and Potassium Content in Switchgrass Plants Collected from a Fall and Spring Harvest	70
Table 4.2: SRF Present Value of Costs of Production in Function of Mean Annual Yield Increment	72
Table 4.3: Energy Ratio for SRF Willows for Different Mean Annual Yield Increments	73
Table 4.4: Carbon Requirement Based on Fossil Fuel Used for SRF Willows for Different Mean Annual Yield Increments	74
Table 4.5: Switchgrass Present Value of Costs of Production in Function of Average Annual Productivity	75
Table 4.6: Switchgrass Energy Ratio for Different Average Annual Productivity	76
Table 4.7: Switchgrass Carbon Requirement Based on Fossil Fuel Use for Different	

Appendix 1: Cropping Practices for SRF Willows, Switchgrass, and Corn

A1.1.1 Cropping Practices for SRF Willows – Seedfarm	A1-1
A1.1.2 Cropping Practices for SRF Willows – Ecomuseum	A1-2
A1.2.1 Cropping Practices for Switchgrass – Seedfarm	A1-3
A1.2.2 Cropping Practices for Switchgrass – Ecomuseum	A1-4
A1.3.1 Cropping Practices for Corn – Seedfarm	A1-5
A1.3.2 Cropping Practices for Corn – Ecomuseum	A1-6

Appendix 3: Additional Tables for Chapter 4

Table A3.1: Base Case Values for Cropping Systems	A3-1
Table A3.2: Energy Budget Breakdown for Cropping Systems	A3-1
Table A3.3: Carbon Budget Breakdown for Cropping Systems	A3-2
Table A3.4: Estimated Use of Fossil Fuel Energy and Carbon Emitted over the Life Span of SRF Willow Plantation	A3-3
Table A3.5: Estimated Use of Fossil Fuel Energy and Carbon Emitted over the Life Span of Switchgrass – Spring	A3-3
Table A3.6: Estimated Use of Fossil Fuel Energy and Carbon Emitted over the Life Span of Switchgrass – Fall	A3-4

Appendix 4: Model Simulation Results for SRF Willow

Table A4.1: Summary of SRF Willow Results	A4-1
Table A4.2: Economic Budget for SRF Willows	A4-2
Table A4.3: Energy Budget for SRF Willows	A4-3
Table A4.4: Carbon Budget for SRF Willows	A4-4
Table A4.5: Simulation Results for SRF Willows	A4-5

Appendix 5: Model Simulation Results for Switchgrass – Spring

Table A5.1: Summary of Switchgrass - Spring Results	A5-1
---	------

Table A5.2: Economic Budget for Switchgrass – Spring	A5-2
Table A5.3: Energy Budget for Switchgrass – Spring	A5-3
Table A5.4: Carbon Budget for Switchgrass – Spring	A5-4
Table A5.5: Simulation Results for Switchgrass – Spring	A5-5

Appendix 6: Model Simulation Results for Switchgrass – Fall

Table A6.1: Summary of Switchgrass - Fall Results	A6-1
Table A6.2: Economic Budget for Switchgrass - Fall	A6-2
Table A6.3: Energy Budget for Switchgrass – Fall	A6-3
Table A6.4: Carbon Budget for Switchgrass – Fall	A6-4
Table A6.5: Simulation Results for Switchgrass – Fall	A6-5

List of Figures

Chapter 1: Introduction

Figure 1.1: Organization of Study	3
-----------------------------------	---

Chapter 2: Background Information on Bioenergy Feedstocks

Figure 2.1: Ecomuseum Site	6
Figure 2.2: Seedfarm Site	7

Chapter 3: Carbon Storage Study

Figure 3.1: The Seedfarm Site	20
Figure 3.2: The Ecomuseum Site	20
Figure 3.3: Mean aboveground yield of corn, switchgrass, and willow at the at the Seedfarm and Ecomuseum sites, at the end of the 1996 and 1997 growing Seasons	29
Figure 3.4: Mean aboveground yield (excluding weeds and litter) of corn, switchgrass and willow at the Seedfarm and Ecomuseum at the end of the 1998 growing season	30
Figure 3.5: Mean aboveground carbon content of corn, switchgrass, and willow at the Seedfarm and Ecomuseum sites, at the end of the 1996 and 1997 growing seasons.	31
Figure 3.6: Mean root yield for corn, switchgrass, and willow.	35
Figure 3.7 Mean fine root yields of corn, switchgrass, and willow, at the Seedfarm and Ecomuseum sites, at various depth intervals.	36
Figure 3.8 Mean root carbon for corn, switchgrass, and willow, at the Seedfarm and Ecomuseum sites, at the end of the 1996 and 1997 growing season.	38
Figure 3.9: Mean root carbon accumulations of corn, switchgrass, and willow, at the Seedfarm and Ecomuseum sites, at various depth intervals.	39
Figure 3.10: Mean soil organic carbon in corn , switchgrass, willow, abandoned field, and forest, in an equivalent soil mass of 7090 t/ha.	45
Figure 3.11: Mean 1998 soil organic carbon levels in corn, switchgrass and willow, in an equivalent soil mass of 6910 t/ha	45
Figure 3.12: Comparison of soil organic carbon levels measured in 1996 and 1998 in corn, switchgrass and willow at the Seedfarm and Ecomuseum sites	47

Figure 3.13: Total plant biomass yield for 1996 for corn, switchgrass, willow, and 1997 plant biomass for abandoned field, and forest.	49
Figure 3.14: Total organic carbon in 1996 in the plant biomass and soil for corn, switchgrass, willow, and total organic carbon measured in 1997 in the plant biomass and soil for abandoned field, and forest.	50
Figure 3.15: Mean carbon partitioning in switchgrass, willow, and corn at the Seedfarm and Ecomuseum sites in 1996.	53

Chapter 4: Economic, Energy, and Carbon Budgeting

Figure 4.1: Economic Cost Breakdown for SRF Willow	72
Figure 4.2: Carbon Budget Breakdown for SRF Willow	73
Figure 4.3: Carbon Requirements for SRF Willow	74
Figure 4.4: Economic Cost Breakdown for Spring and Fall Switchgrass	76
Figure 4.5: Carbon Budget Breakdown for Spring and Fall Harvested Switchgrass	77
Figure 4.6: Carbon Requirements for Spring and Fall Harvested Switchgrass	78
Figure 4.7: Comparison of Carbon Requirements for Cropping Systems	79
Figure 4.8: Energy Budget for Cropping Systems	81

List of Symbols

BTU	British Thermal Unit
C	elemental carbon
GHG	greenhouse gas(es)
GJ	Gigajoule = 0.9478 MBTU
cm	centimeter
cmol	centi-mole = 0.01*1 mole
CO ₂	carbon dioxide
g	gram
ha	hectare = 2.47 acres
HHV	higher heating value
K	elemental potassium
kg	kilogram
Mg	Megagram = one metric tonne = 2,200 lbs = 1.1 ton
m	metre
mm	millimetre
N	elemental nitrogen
n.a.	not available
odMg	oven dried Megagram
odt	oven dried tonne (metric)
P	elemental phosphorous
ppm	parts per million = 1 mg L ⁻¹
SNK	Student-Newman-Keuls statistical test for comparisons
SRF	short rotation forestry
t	tonne
tonne	one metric tonne- one Megagram = 1.1 ton
yr	year
\$	Canadian dollar
°C	degrees Celsius

Chapter 1

INTRODUCTION

In Kyoto, Canada pledged to reduce its greenhouse gas (GHG) emissions by the years 2008-2012, to a level at least 6% below its 1990 greenhouse gas emission level (UNFCCC, 1997). The leading GHG is carbon dioxide (CO₂), followed by methane (CH₄) and nitrous oxides (NO_x) (IPCC, 1995). In order for Canada to achieve these reductions in emission rates, several strategies are available: 1. increase energy use efficiency; 2. develop renewable energy sources, and 3. develop new carbon sinks.

When energy is produced using plant biomass, the opportunity exists to address the greenhouse effect through the latter two strategies. During photosynthesis, plants transform CO₂, water, and solar energy into biomass and oxygen. The consequent carbon release into the atmosphere from the burning of biomass stems from the carbon incorporated into the plant tissue that was trapped from the atmosphere during the growing cycle. The carbon released is thus effectively recycled into the plant biomass through photosynthesis. The only net CO₂ loading in a biofuel system results from the use of fossil fuels during the production and processing of the biomass crop. Nonetheless, when perennial biomass crops are used to produce bioenergy feedstocks, the potential exists to sequester carbon in the soil, creating a carbon sink. This sink may even more than offset the release of carbon stemming from the cultivation and processing of the feedstocks.

Perennial biomass crops such as switchgrass (*Panicum virgatum* L.) and short rotation forestry (SRF) plantations are examples of crops that are able to achieve reductions in atmospheric CO₂ loading through fossil fuel substitution and at the same time possibly act as carbon sinks. Perennial crops also have the potential to reduce soil erosion and nutrient leaching due to their permanent ground cover and more extensive root systems than conventionally grown cash crops. The development of a biomass-to-biofuel industry would benefit the farm economy by introducing new markets for agricultural products, and create jobs in rural regions, as processing plants are likely to be located near the source of raw biomass material.

1.1. Objectives

The broad objective of this study was to develop economic, energy, and carbon emission budgets associated with the cultivation of switchgrass and SRF willow plantations grown as part of a CO₂ offset strategy in eastern Canada.

Specific objectives were to:

1. evaluate the potential for soil carbon storage, and below- and aboveground plant carbon storage, in commercial switchgrass and SRF willows plantations;
2. conduct an on-site comparison of the carbon sequestering potential of perennial biomass crops to a commercial row crop;
3. develop energy, carbon and economic budgets associated with the production of switchgrass and SRF willows;
4. assess the final carbon offset potential for switchgrass and SRF willow biomass feedstocks using carbon requirement ratios.

Figure 1.1 shows the organization of the study (see next page).

1.2. Scope

The field experiments for this three-year study were conducted on two 5-hectare sites using three crops: switchgrass (*Panicum virgatum* L.), short rotation forestry willows (*Salix alba x glatfelteri* L.), and corn (*Zea mays* L.). Short rotation forestry willows and switchgrass had been grown on the sites for three years when this project was initiated in 1996. Corn was introduced on the sites in 1996. All three crops were grown on areas of St. Bernard and Chicot fine sandy loam, with some pockets of Chateaugay clay loam. The field productivity assessments presented in Chapter 2 were performed randomly across the plots, regardless of soil type. All sampling in Chapter 3 was restricted to areas of Chicot fine sandy loam. Both experimental sites were located in southwestern Quebec. Therefore all results and recommendations of this study pertain only to similar climatic and soil conditions.

The model used to investigate the economics, energy requirements and carbon emissions associated with the cultivation of SRF willows and switchgrass was developed in accordance with the most recent research information available. Assumptions used and limitations of the analysis are stated in Chapter 4.

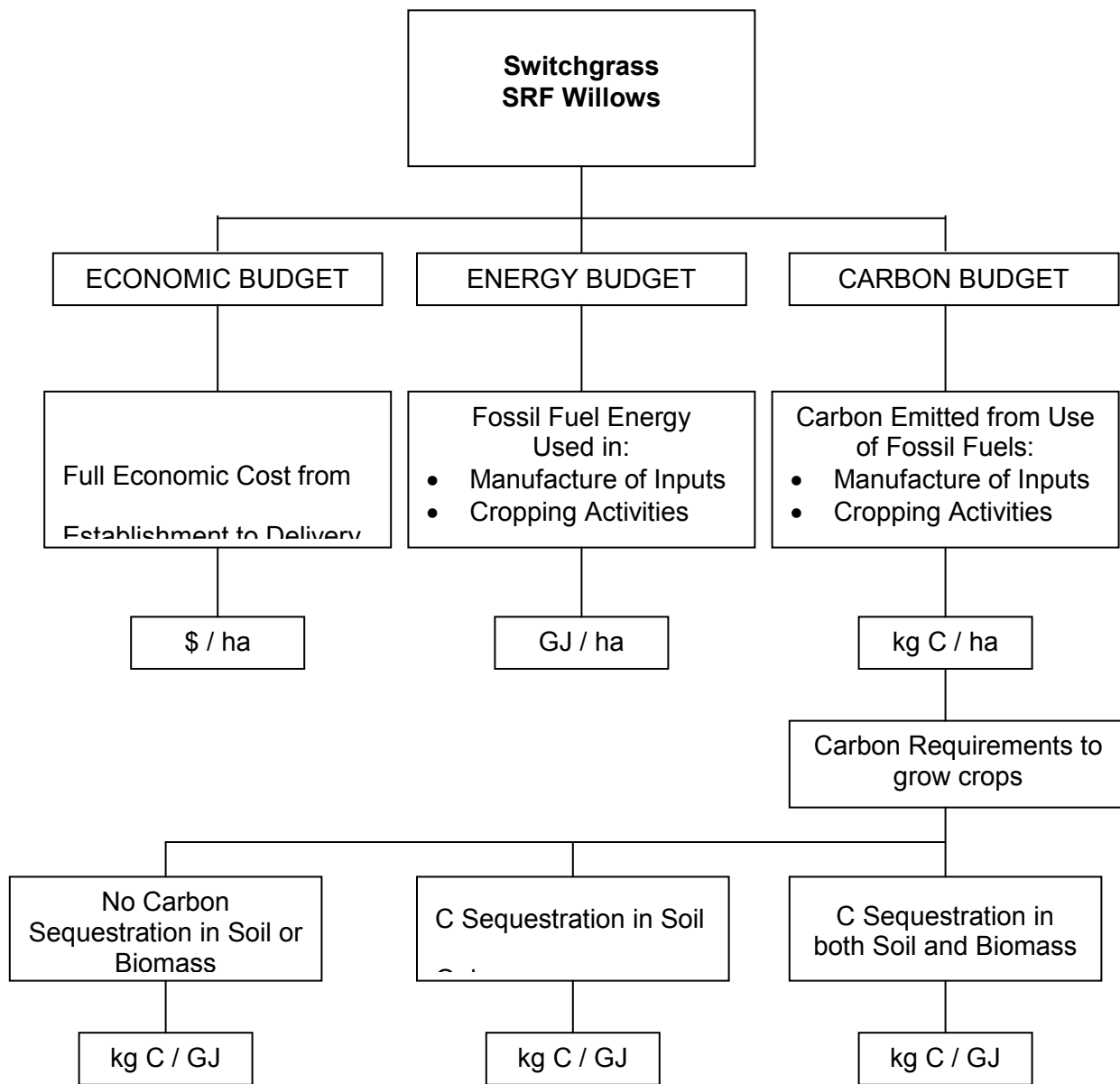

Figure 1.1. Organization of Study

Chapter 2

FIELD PRODUCTIVITY ASSESSMENTS OF BIOENERGY FEEDSTOCKS

Switchgrass and short rotation forestry (SRF) willows were grown on quasi-commercial size plantations, monitored by REAP-Canada, since 1993 in Ste-Anne-de-Bellevue, Quebec. The establishment methods, cropping and maintenance practices, and biomass yields up until, and including, 1995 are described in an earlier report (Samson et al., 1995). This chapter contains some of the background information on the maintenance and harvestable biomass yields attained from 1996 to 1998 for switchgrass, SRF willows and corn.

2.1. Site Background and Description

Two sites were established in 1993 by REAP-Canada to evaluate the adaptability and potential productivity of different varieties of SRF willow and switchgrass, a warm-season perennial grass. Both sites (Ecomuseum and Seedfarm), of approximately 5 hectares each, were located on the Emile Lods Agronomy Research Centre of McGill University in Ste-Anne-de-Bellevue, Quebec (42°25'N lat., 75°56'W long.).

The sites were identified as “Ecomuseum” and “Seedfarm”, and represented two different levels of productivity at the onset of the experiment, with the Ecomuseum being inherently more fertile, and the Seedfarm less fertile. The Ecomuseum site received regular dairy manure applications of approximately 20 Mg/ha/yr. The field was considered of good quality for row crop production and hence was mostly under corn production for the past twenty years. The Seedfarm site had a hard pan layer at approximately 30 cm, and had some areas which were prone to summer water deficiencies, and therefore had limitations for row crop production, such as corn. Prior to 1993, the field was mostly in a corn-alfalfa rotation.

Both sites were composed mainly of a Chicot fine sandy loam, with some areas of St-Bernard loam, as well as pockets of Chateauguy clay loam. The assessment of soil texture, in 1993, at the two sites revealed sand, silt and clay contents of 48.6%, 35.0% and 16.4%, respectively for the Seedfarm, and 64.0%, 19.5% and 16.6%, respectively for the Ecomuseum (Samson et al., 1995). From these soil compositions, the soil at the Seedfarm was primarily deemed to be a loam, while the Ecomuseum was a fine sandy loam.

Both sites had the same experimental design, which consisted of 6 blocks (replications) at each site, with 3 treatments (willow, switchgrass, and corn) in each block, arranged in a randomized complete block design (RCBD).

The plots used for the corn treatments were former plots of SRF willows that were planted in 1994. These SRF willows were mowed and plowed under at both sites, in the summer of 1995 (as the clones suffered from recurring pest infestations from the willow sawfly (*Nematodes* sp.)). The mowed material, approximately 2-4 od (oven dried) Mg/ha, was left on the surface and incorporated into the soil during the plowing process. In the spring of 1996, these plots were planted to corn, so as to measure carbon storage in an annual row crop (Chapter 3). The layout of the Ecomuseum and the Seedfarm are shown in Figures 2.1 and 2.2.

Ecomuseum Site

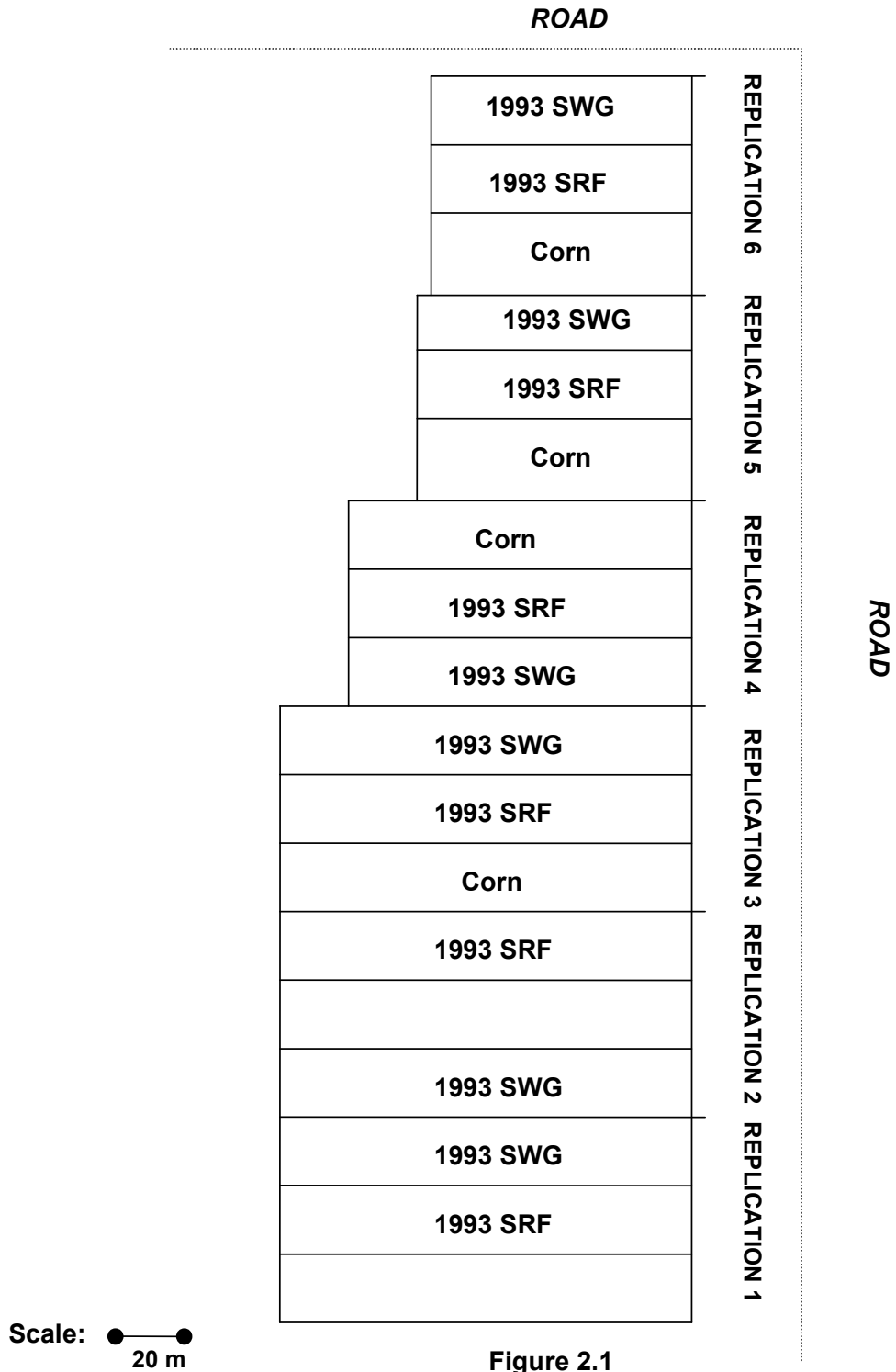

Figure 2.1

Seed Farm Site

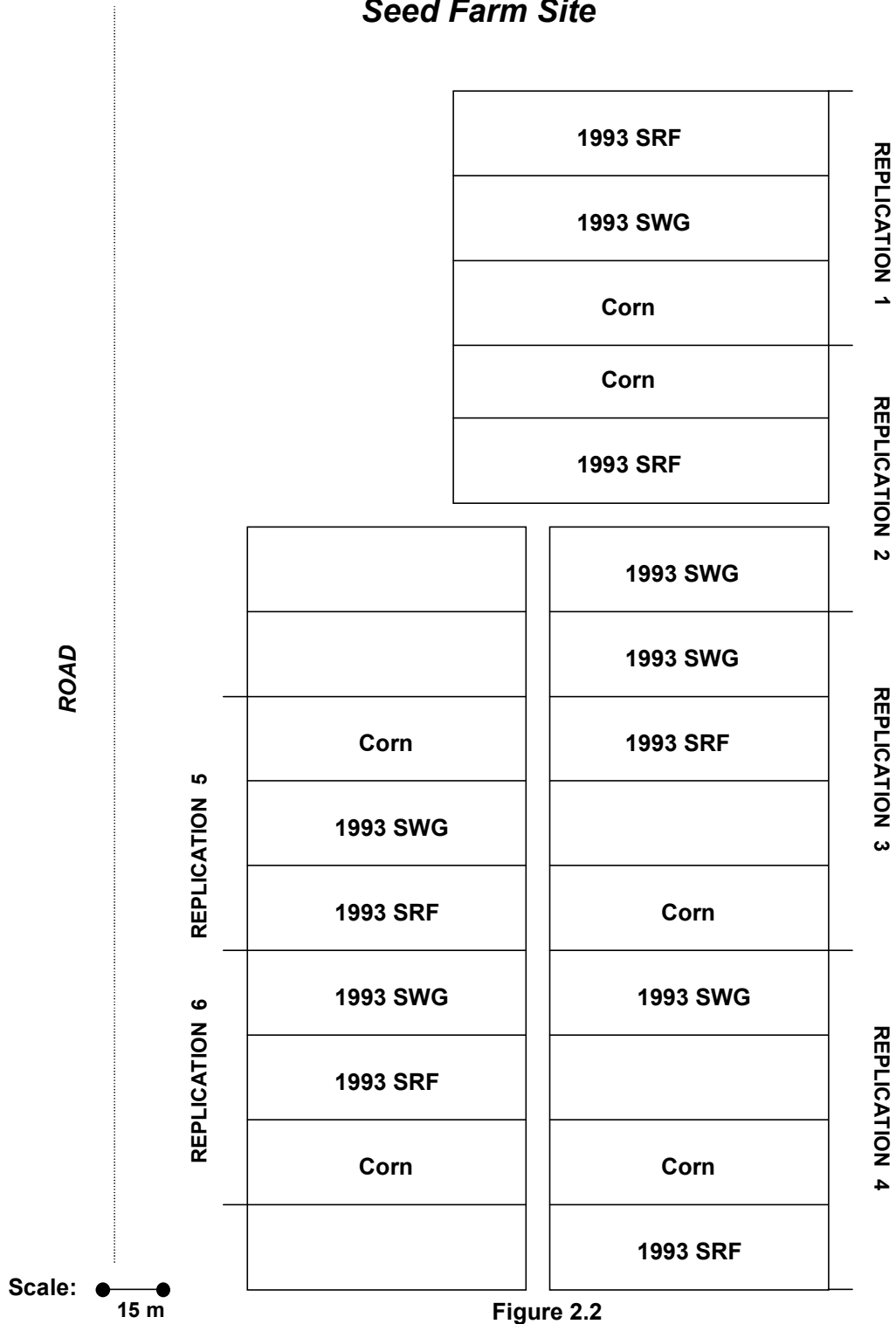

Figure 2.2

2.2. Cropping Regime

2.2.1. SRF Willows

The SRF willows used in this study were planted in the spring of 1993 and coppiced during the winter of 1996 (January 1996), after 3 years of growth. The coppicing was undertaken to allow the study to begin with a new harvest cycle (cycle 2 in Table 2.4), which is more representative of the potential crop growth the plots have to offer. The stands were considered to be fully established after coppicing. Cropping practices for 1993 to 1995 are presented in detail in Samson et al. (1995) and summarized in Appendix 1.

The spacing between each tree was 0.92 m, giving rise to a planting density of approximately 11,000 trees/ha, with a survival rate of approximately 9,500 trees/ha at the Seedfarm and 10,000 trees/ha at the Ecomuseum site. The coppiced trees at both sites were fertilized in June 1996 with 77 kg N/ha and 84 kg K/ha. Based on soil tests, it was determined that phosphorus application was not necessary. The trees at the Seedfarm site were sprayed with quizalofop ethyl (Assure[®]) in July 1996, for grass weed control. No fertilizer or herbicide applications were performed during the 1997 growing season. In 1998 the trees were fertilized with 125 kg N/ha, 31 kg P/ha and 75 kg K/ha.

Short Rotation Forestry willow yields were assessed in December 1996, 1997 and 1998 by harvesting two randomly selected areas (each consisting of two rows x 5 meters long) in every plot, at a height of 10 cm. A representative tree from each plot was chopped and oven-dried to determine the dry weight for the yield calculations.

2.2.2. Switchgrass

Switchgrass plots were also seeded in 1993 (for details see Samson et al., 1995). The stands were considered to be fully established in their third growing season, in 1995. A full description of the establishment and cropping practices between 1993 and 1995 are outlined in Samson et al. (1995) and summarized in Appendix 1.

The biomass produced on these sites was left to overwinter after each growing season and was harvested the following May, prior to spring re-growth. Following harvesting, starting in 1994, the stands at both sites were fertilized each year with 50 kg N/ha as urea. In 1997, an additional 25 kg N/ha was applied at the Seedfarm site, 4 weeks after the first application, due to a slight yellowing of the switchgrass. A period of hot dry weather followed the first urea

application in 1997, which may have caused some urea volatilization. No herbicide was sprayed following establishment, and no insect or disease problems were experienced.

Beginning in 1994, fall switchgrass yields were assessed, at both sites, by hand-sickling four 1 m² quadrats, at a cutting height of 10 cm in each plot. A 200 g subsample from each sample was obtained and oven-dried for 24 hours to determine the dry weight.

2.2.3. Corn

Grain corn was sown in May from 1996 to 1998, initially on the plowed down SRF willow plots, described in section 2.1. Secondary spring tillage, prior to planting, consisted of disking in 1996 and 1998, and harrowing in 1997. Sowing was performed using a four-row corn seeder. Corn hybrid Pioneer[®] 3921 was sown in 1996, Pride[®] K206 in 1997, and Pioneer 3893 in 1998. An average density of 80,000 plants per hectare was achieved in all years.

The average rate of fertilizer application over the three years was 170 kg N/ha, 77 kg P/ha, and 65 kg K/ha. In 1996, the weed control consisted of a combination of mechanical (inter-row cultivation) and chemical methods (metolachlor (Dual[®]) and dicamba/atrazine (Marksman[®]) applied as post-emergent herbicides. The same chemical control was used in 1997, but no inter-row cultivation was performed. In 1998, dimethenamid and a mixture of dicamba/atrazine, as well as bentazon were applied. Harvesting of the grain corn took place each year in October, using a conventional corn combine with an eight-row header. The stalks and leaves remained on site and were incorporated into the soil during plowing. Cropping practices for each year, and site, are summarized in Appendix 1.

Grain corn yields were evaluated in October from 1996 to 1998. Samples were harvested from two randomly selected areas (each consisting of two rows x 5 meters long) in the center of each plot. The samples were subsequently shelled and dried, to determine moisture content and dry yield.

2.3. Growing Conditions

The experimental sites were situated on the western side of the island of Montreal. On the southeastern side of the island of Montreal, the St. Lawrence River flows from east to west. On the north side of the island, Riviere des Prairies flows from east to west. The Lac des Deux Montagnes and the Lac St-Louis are situated on the west side of the island. Due to the region's

abundance of rivers and lakes, the West Island is noted for its microclimate. It receives sufficient precipitation throughout the year; total average precipitation from May to September is 423 mm (Table 2.1), and has hot, humid summers (Table 2.2) with corn heat units (CHU) reaching >3,000 for the growing season (Table 2.3). The Montreal/Dorval International Airport is located approximately 20 km east of the research station, while the Les Cedres meteorological station is approximately 15 km west of the research station, both at similar latitudes to the site. Throughout the duration of the study, monthly precipitation was relatively normal during the growing season, with the exception of higher than normal precipitation in April and May of 1996 and July 1997, and lower than normal in August 1996, and April and May of 1998. Temperatures were near the normal range in 1996 and 1997 with the exception of a cool May in 1997. In 1998 the temperature was higher than normal, especially during the early spring (in May 1998, the average temperature was 4.5°C above the normal) and fall period, which extended the growing season. The CHU for the region followed the mean, with a minimum amount of deviations.

Table 2.1. Total monthly precipitation (mm) from 1993-1998 from Montreal/Dorval International Airport (Environment Canada)							
	Total monthly precipitation (mm)						
	1993	1994	1995	1996	1997	1998	Normal
January	118.6	88.8	112.2	67.4	120.0	158.4	63.3
February	65.4	65.4	58.0	72.2	96.4	63.8	56.4
March	70.0	64.4	45.9	16.4	n.a.	128.5	67.6
April	152.2	100.2	70.2	177.8	96.9	35.0	74.8
May	86.7	100.4	81.5	92.0	76.0	50.5	68.3
June	93.4	143.8	56.6	65.5	104.5	74.5	82.5
July	90.2	50.6	122.1	106.0	135.0	89.5	85.6
August	43.6	84.6	127.4	22.5	106.4	92.5	100.3
September	122.6	67.2	59.6	115.1	91.5	62.0	86.5
October	123.2	19.8	182.7	74.5	49.3	62.5	75.4
November	98.2	118.7	136.7	163.8	90.0	35.7	93.4
December	65.8	59.8	68.1	89.4	56.6	55.0	85.6

n.a., not available

Table 2.2. Mean monthly temperature (°C) from 1993-1998 from Montreal/Dorval International Airport (Environment Canada)

	Mean monthly temperature (°C)						
	1993	1994	1995	1996	1997	1998	Normal
January	-8.8	-16.6	-6.3	-10.7	-10.4	-7.3	-10.3
February	-14.1	-11.8	-9.9	-7.9	-7.9	-3.8	-8.8
March	-4.0	-3.0	-0.4	-2.5	n.a.	-0.8	-2.4
April	5.9	5.3	3.7	5.0	4.8	8.1	5.7
May	13.1	12.1	13.1	12.3	10.7	17.4	12.9
June	17.6	19.1	20.2	18.6	20.1	19.5	18.0
July	21.5	21.8	22.2	20.2	20.6	21.1	20.8
August	20.9	18.2	20.2	20.4	19.0	21.0	19.4
September	14.1	14.8	13.4	16.3	14.6	16.1	14.5
October	6.5	9.4	11.2	8.1	8.0	9.8	8.3
November	1.3	3.7	-1.0	-0.4	0.7	3.5	1.6
December	-5.6	-3.5	-8.6	-1.3	-5.7	-1.7	-6.9

n.a., not available

Table 2.3. Cumulative Total Corn Heat Units at selected dates from 1993-1998 from Les Cedres Agriculture Canada Meteorological Station							
	Total Corn Heat Units (Base 10 °C)						Mean (1961-90)
	1993	1994	1995	1996	1997*	1998*	
January							
February							
March							
April							
May	203	202	254	204	209	125	273
June	824	895	989	883	936	836	918
July	1667	1749	1827	1690	1723	1643	1726
August	2491	2457	2616	2498	2452	2447	2484
September	2965	2983	3070	3083	2943	3014	2992
October	3080	3223	3400	3259	3011	3065	3203
November							
December							

*, data calculated from maximum and minimum temperatures at Montreal- Dorval weather station, monitored by Environment Canada.

2.4. Harvestable Biomass Yields

Harvestable biomass yields for the three crops were estimated at the end of the 1996, 1997 and 1998 growing seasons, by hand harvesting random samples from each cropping system, as outlined in section 2.2 “Cropping Regime”.

2.4.1. SRF Willows

Harvestable annual yield increments in 1996 (the first year following coppicing) were lower than in 1995 (Table 2.4). Yields were observed to decline by approximately 30% from 1995 to 1996, due to coppicing. Previous research has shown willows to be vulnerable to yield reductions in the first year following coppicing (Willebrand, 1995).

From 1994 to 1996, the Seedfarm experienced a significant insect infestation from the European sawfly (*Nematus* sp.). In 1996 the problem was most severely noted on the trees in blocks (replicates) 5 and 6, which were almost entirely defoliated by sawfly larvae in June. These trees had to re-establish their canopy in early summer, which may have depleted energy reserves for the following year. However, unlike the previous two years, no additional insect

problems were experienced later in the summer of 1996. Based on previous observations at this site, it appeared that the more mature trees were less affected by the insect infestations than the nitrogen rich, juvenile, material. No nitrogen fertilization was applied to the plots in 1997 in order to avoid stimulating further pest problems. There were no visual signs of nitrogen deficiencies in 1997, and no pest outbreaks occurred.

At the Ecomuseum site, very little insect damage was observed in 1996, however, significant growth problems were experienced in some areas of block (replicate) 6. The trees appeared to be stunted and to have a reduced population, which may have coincided with the patches of St. Bernard soil. This soil type can contain large subsurface boulders in the surface 60 cm, which may hinder proper root development. Coppicing the trees may have also have induced some stand mortality due to a combination of disease and water stress of the regrowing stumps.

In 1997, the annual yields of the clone tested willow (*Salix alba x glaufelteri*) was 7.2 odMg/ha and 9.6 odMg/ha at the Seedfarm, and the Ecomuseum, respectively (Table 2.4). These yields represented an average annual incremental increase of 1.3 odMg/ha, for both sites, when compared with 1996. However, the average incremental yield at the Seedfarm was rather low, at 7.2 odMg/ha. This yield was 38% lower than in 1995, (the pre-coppicing year) of 11.6 odMg/ha. This low yield in 1997 may have been caused by a combination of factors at this site. The trees may have lost some of their root reserves for the winter of 1996/97, after undergoing the summer defoliation stress in 1996.

Site	1994 [‡]	1995	1996	1997	1998*	Five-Year Average
	1st cycle	1st cycle	2nd cycle	2nd cycle	2nd cycle	
Seedfarm [†]	4.4	11.6	6.6	7.2	25.6	11.1
Ecomuseum	9.4	8.8	7.6	9.6	15.3	10.1
Average	6.9	10.2	7.1	8.4	20.5	10.6

[‡] Total increment for 1993 and 1994.

*Sampled in April 1999, due to technical difficulties with samples in November 1998

[†] Does not include block 4

Means within a column followed by the same letter, or no letter, are not significantly different at $P > 0.05$ level according to Duncan's Multiple Range test.

In 1998, willow growth was exceptional on both sites. The combination of timely rainfall, adequate fertility, no major insect problems and an extended growing season in the spring and

fall (Table 2.2), created ideal growing conditions for the willows. The annual growth increment at the Seedfarm excelled at 25.6 odMg/ha. At the Ecomuseum, the willows had an annual yield increment, in 1998, of 15.3 odMg/ha, which represented a 59% incremental yield increase compared to the previous year. In spite of these seemingly large yield differences between the sites in 1998, no significant site difference was found, possibly due to standard errors of ± 3.8 odMg/ha at the Seedfarm, and ± 3.6 odMg/ha at the Ecomuseum. However, the five-year average yield was fairly similar for both sites (11.1 odMg/ha at the Seedfarm, and 10.1 odMg/ha at the Ecomuseum (Table 2.4)), considering the different rates of growth obtained over the growing season.

The incremental yields obtained for individual years were more variable at the Seedfarm, than at the Ecomuseum, which had fairly consistent yield increments. This may have been due to the culmination of encountering more problems at the Seedfarm, including weed establishment in 1994, and the serious mid summer defoliation problems in 1996 (which may have carried over into affecting the 1997 yields). The lower SRF willow yields obtained, on both sites, in the early plantation years (1993-1995) are common, as similar plantation yields of 5.3 – 8.3 odMg/ha have been found in 3 year old plantations in Quebec (Lebreque and Teodorescu, 1998).

2.4.2. Switchgrass

The average total yield of the three switchgrass varieties increased from 1994 to 1997, indicating that it may take switchgrass stands three years to become fully established in a temperate climate. The individual yields of the switchgrass cultivars were also shown to increase in successive years, except for the Cave-In-Rock variety at the Seedfarm site in 1997 and at the Ecomuseum in 1998. In 1998, the Sunburst variety at both sites, also had lower yields than in 1997. The five-year averages for each site and across varieties were not significantly different from each other at 11.2 and 10.5 odMg/ha at the Ecomuseum and Seedfarm, respectively. These yields were similar to the average total 5-year willow yield of 10.6 odMg/ha/yr.

In 1996, the Cave-in-Rock variety had significantly higher yields than the other varieties at the Seedfarm (Table 2.5). At the Ecomuseum, both Cave-In-Rock and Pathfinder varieties had significantly higher yields than the Sunburst variety. In 1995, 1997 and 1998, no significant difference was observed between cultivar yields either at the Seedfarm or the Ecomuseum site.

In 1998, when pooling the variety data, the Seedfarm had significantly higher overall switchgrass yields (12.9 Mg/ha) than the Ecomuseum (11.4 Mg/ha) (data not shown).

The Cave-in-Rock variety used for assessing carbon storage in Chapter 3, had a five-year average yield of 11.3 odMg/ha/yr (mean of both sites). Although all sites were harvested in the fall, research has shown that approximately 24% of switchgrass biomass is lost through the overwintering process (Goel et al., 1998). The material lost over winter contributes to litter build up and helps to regenerate the soil. Overwintering improves the quality of the material for combustion or papermaking. The spring also provides more appropriate weather conditions for carrying out harvesting operations, ensures good winterhardiness, and reduces fertilizer costs by allowing the nutrients to be recycled into the soil.

Cultivar	1994	1995	1996	1997	1998	Five-Year Average
	odMg/ha					
Seedfarm Site						
Cave-in-Rock	9.7 ab	11.0	11.9 a	11.7	13.7	11.6
Pathfinder	9.9 a	10.9	11.3 b	11.6	13.2	11.4
Sunburst	8.8 b	9.5	10.9 b	12.0	11.9	10.6
Ecomuseum Site						
Cave-in-Rock	7.9	9.6	12.7 a	13.5	11.3	11.0
Pathfinder	7.4	9.7	11.3 ab	12.8	12.2	10.7
Sunburst	7.0	8.5	10.1 c	12.4	10.7	9.7
Average Yield	8.5	9.9	11.4	12.3	12.2	10.9

Means within a column followed by the same letter, or no letter, within a site are not significantly different at the 0.05 level according to Duncan's Multiple Range test.

2.4.3. Corn

In 1996, grain corn yields were high on both sites considering the relatively late sowing date of May 29 (Table 2.6). Yields at the Seedfarm and at the Ecomuseum were 8.6 odMg/ha and 8.3 odMg/ha, respectively. In 1997, poor germination, poor weed control, and herbivore damage contributed to low yields, resulting in no data being collected for some plots, at both sites. In 1998, an early growing season and mild weather contributed to a productive growing season for corn. Grain yields attained an average of 8.0 odMg/ha, on both sites, with no pest problems, and little to no weed problems experienced. Corn stalk and leaf biomass data are presented in Chapter 3.

Site	1996 ^a	1997 ^b	1998 ^c	Average of 1996, 1998
	odMg/ha			
Seedfarm Site	8.6	5.9	7.8	8.2
Ecomuseum Site	8.3	n.a.	8.1	8.2
Average	8.5	n.a.	8.0	8.3

^a Hybrid Pioneer 3921

^b Hybrid Pride K206

^c Hybrid Pioneer 3893

n.a., not available because of pest damage

Means within a column followed by the same letter, or no letter, are not significantly different at the 0.05 level according to Duncan's Multiple Range test.

2.4.4. Comparisons Between Willow, Switchgrass, and Corn

The mean yields, from 1996 to 1998, on the two fully established plantations of switchgrass and SRF willows were very similar, at 12.0 and 12.3 odMg/ha, respectively (Table 2.7). Therefore, both of these biomass crops can obtain relatively productive yields once fully established. However, SRF willow yields were more variable within each year, while the switchgrass yields were more stable.

Switchgrass had consistent yields across the plantations, in contrast to the SRF willow, where the most variable results were found at the Seedfarm. The switchgrass yields were almost identical at both sites (12.2 and 12.5 odMg/ha, at the Seedfarm and the Ecomuseum, respectively), while overall, the SRF willow at the Seedfarm had 21% higher yields than at the Ecomuseum (Table 2.7).

The corn plots had productive grain yields in 1996 and 1998. The microclimate of the region, as well as the relatively high CHU are usually beneficial factors for the production of corn. Nevertheless, the average grain yield of the corn was approximately one third lower than that of the two perennial crops, with two-year average grain yields for both sites of 8.2 odMg/ha. A three year corn yield average for the sites would be approximately 7.5 odMg/ha, assuming a harvestable yield of 5.9 odMg/ha (same as for the Seedfarm) was obtained for the Ecomuseum in 1997.

At the onset of the experiment, the Ecomuseum site was of inherently higher soil fertility, due to the many years of dairy manure application. However, after 6 years without manure application

at either site, the Seedfarm site is beginning to emerge as the more productive site. The soil texture analysis indicated the Seedfarm to have, from its composition, a more productive soil texture (loam classification), as opposed to the fine sandy loam classification of the Ecomuseum.

Table 2.7. Average 1996-98 Yields of Short Rotation Forestry Willow, Switchgrass and Grain Corn at the Plantation Sites in Ste-Anne-de-Bellevue, Quebec				
	Variety	Seedfarm	Ecomuseum	Average
			odMg/ha	
Short Rotation Forestry	Salix alba x glatfelteri	13.1	10.8	12.0
Switchgrass	Cave-In-Rock	12.2	12.5	12.3
Corn*	Grain only	8.2	8.2	8.2

*Corn yield is an average of 1996 and 1998

2.5. Conclusions

The main observations from the plantations, demonstrate that in southwestern Quebec, both SRF willows and switchgrass can have average productive yields of approximately 12 odMg/ha/yr, once they reach full establishment. Switchgrass yields have less variability across years, and sites, while willow yields can vary considerably. Seasons such as those experienced in 1998, with extended growing seasons and timely rainfalls, demonstrate the high yield capacity of SRF willows. Similarly, the trees can have low productivity years when dry summers or heavy pest infestations occur. Both of the perennial biomass crops, however, have demonstrated a high yield potential. Particularly considering the limited plant improvement which has occurred in this region. The *Salix alba x glatfelteri* willow was an imported clone, developed in the former Yugoslavia, and the Cave-In-Rock switchgrass was an unimproved variety, originating from seed gathered from a Southern Illinois prairie. With plant breeding programs specifically targeted to these crops, in this region, yields will undoubtedly be improved.

Chapter 3

CARBON STORAGE STUDY

The primary purpose of this component of the project was to quantify, for the first time, the impact switchgrass and SRF willows have on carbon cycling and carbon sequestering within an agricultural setting, in eastern Canada. Two main objectives were pursued within the scope of this study;

- compare the accumulation of above and belowground plant carbon and soil carbon in SRF willow and switchgrass systems;
- collect soil carbon data for comparison purposes from an intact forest ecosystem and a long-term annual cropping ecosystem, to enable the estimation of long-term soil carbon storage potential under SRF willows and switchgrass systems.

Claudia Zan, a graduate student who worked under the supervision of Dr. James Fyles, in the Department of Natural Resource Sciences at McGill University, performed these components of the study. Chapter 3 presents a summary of the methodology implemented and results obtained. A detailed literature review is presented in Appendix 2. Further details are available in her thesis (Zan, 1998).

3.1 Methodology

The following section describes the methodology (Zan, 1998) used to assess carbon storage on the sites.

3.1.1. Sampling, Site Description and History

Unlike the field productivity assessments carried out by REAP (see Chapter 2), samples referred to in this chapter were obtained exclusively from areas of Chicot fine sandy loam, a soil series belonging to the Grey Brown Podzolic group, to maintain consistency and to reduce the number of statistical variables.

The land under study was undulating to gently rolling, and the soil had a moderate moisture-holding capacity. At 0-20 cm, this soil was characterized as being a dark brown, fine sandy loam with a fine crumb structure and very friable. At 20-40 cm, the soil consisted of a yellow-brown to brown, fine light very friable sandy loam, with a uniform colour and some faint mottling, and a pH of 5.8 to 6.2. At 40-60 cm the soil was characterized as being a brown sandy loam or sandy clay loam with clay loam patches, and moderately friable to slightly firm, with occasional faint mottling, and a pH ranging from 6.0 to 6.4. At deeper layers, the soil was dark brown and characterized as a brown sandy loam with streaks and pockets of sandy clay or clay loam, mottled, with a pH of 6.5 to 6.9. Underlying this soil was calcareous till (Lajoie, 1960). The Seedfarm site was noted as having a plow pan at 30 cm, comprised of very compacted sand, giving rise to an almost gravel-like texture.

Biomass sampling began in October 1996 and consisted of obtaining aboveground and belowground samples of switchgrass, willow, and corn (including litter and weeds). Soil samples, to an average depth of 60 cm were obtained to determine the carbon content within each cropping system. Sampling was carried out in 4 blocks at two sites: Seedfarm (Figure 3.1) and Ecomuseum (Figure 3.2), both situated at the Emile A. Lods Agronomy Research Center, at the Macdonald Campus of McGill University, in southwestern Quebec (42°25'N latitude, 75°56'W longitude). The Seedfarm site was situated in an open field having a south-facing slope, whereas the Ecomuseum site was located on relatively flat, gently sloping land, protected by windbreaks to the east and west.

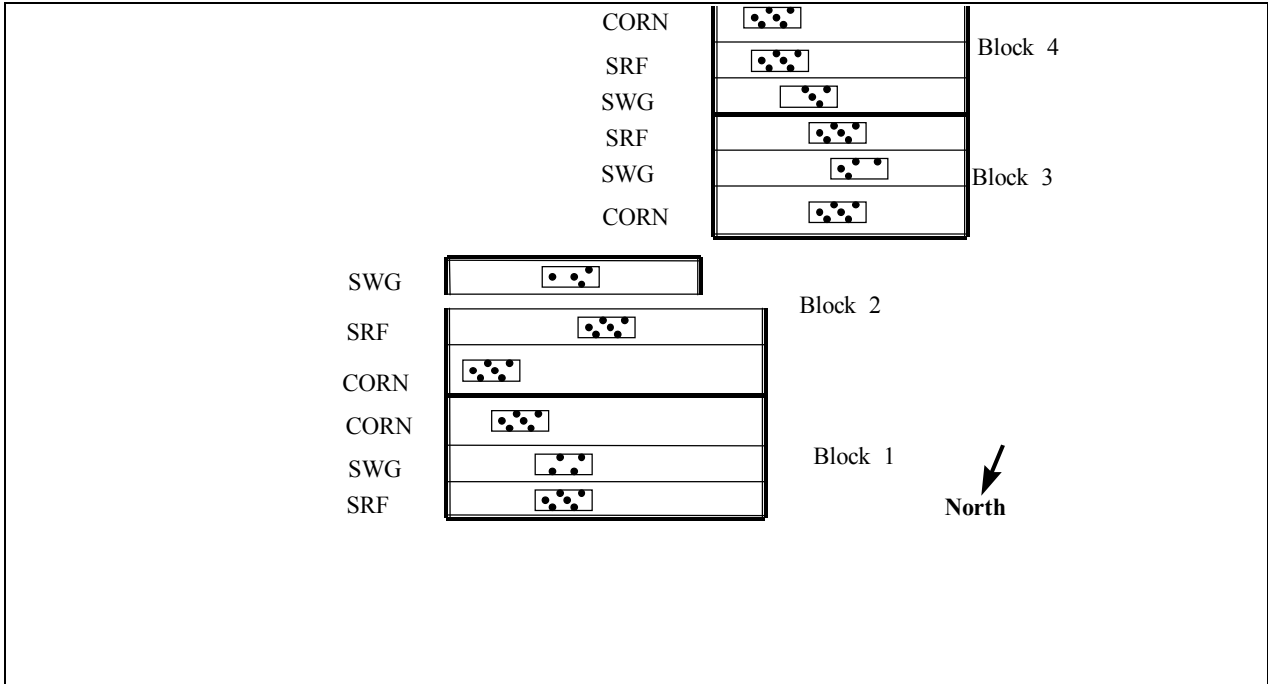

Figure 3.1. The Seedfarm Site. SWG = switchgrass; SRF = willow. The rectangles represent the sampling area (sub-plot) with number of replicates (circles).

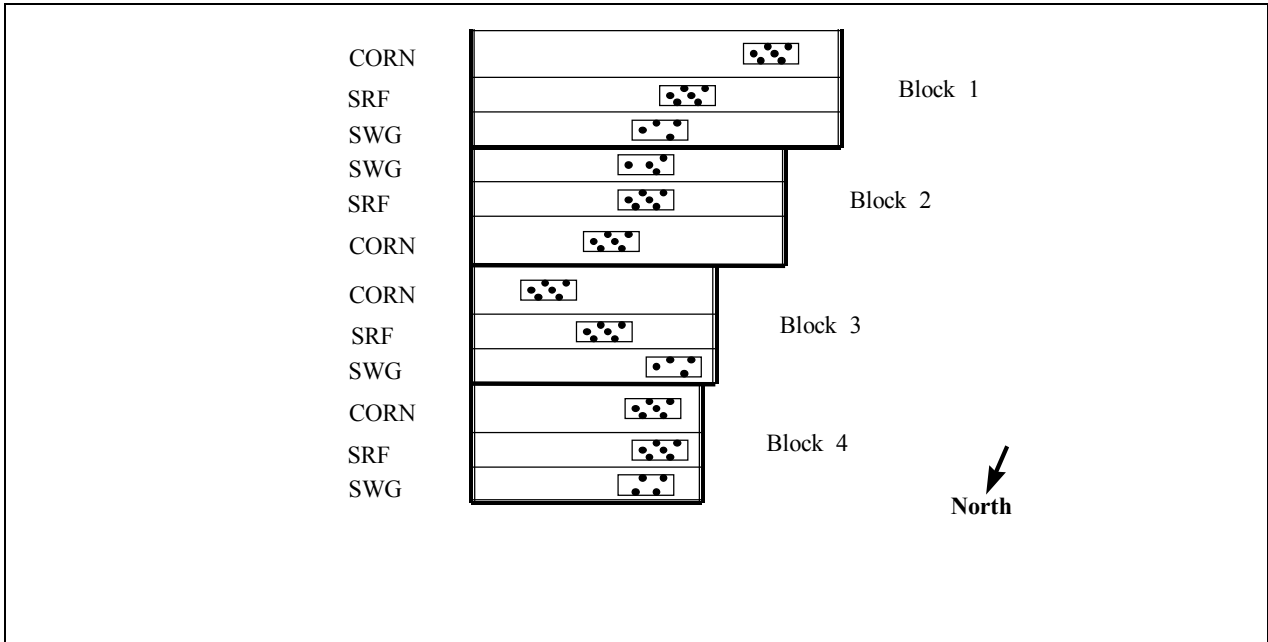

Figure 3.2. The Ecomuseum Site. SWG = switchgrass; SRF = willow. The rectangles represent the sampling area (sub-plot) with number of replicates (circles).

A second sampling was carried out in October 1997 in which only aboveground samples (including litter and weeds) were obtained from the already established switchgrass, willow, and corn plots. In addition, a mature, hardwood forest was sampled in 4 locations to determine the soil carbon content to a 60 cm depth. Two long term abandoned agricultural fields were also sampled for soil carbon and root production (at 2 locations in each). Once again, the soil sampling was restricted to areas of Chicot fine sandy loam.

The forest site was located at the Morgan Arboretum, at the Macdonald Campus of McGill University, and was situated 0.5 km west of the Ecomuseum site. The mature forest consisted of a beech (*Fagus grandifolia*) and maple (*Acer saccharum*) association, aged between 100 and 130 years old. It remained relatively untouched with the exception of salvage work that was being carried out periodically.

The first abandoned agricultural field was located at Stoneycroft Pond, approximately 0.2 km from the Ecomuseum site. The field was cultivated until the late 1970's, and has been abandoned since (Titman R., personal communication). The dominant plant species today is *Bromus tectorum* (junegrass), which makes up roughly 90% of the plant cover. Other species include *Rubus idaeus* (wild raspberry), *Cirsium arvense* (Canada thistle), *Asclepias syriaca* (common milkweed), *Crataegus* sp. (hawthorn bush), *Malus* sp. (apple trees less than 5 years old), and *Solidago canadensis* (goldenrod).

The second agricultural field, also abandoned in the late 1970's, was located at the Morgan Arboretum, close to the mature forest sampling site. The dominant plant species is *Festuca* sp. (fescue), with 99% of the plant cover. Other species include *Asclepias syriaca*, *Cirsium arvense*, *Valeriana officinalis* (common valerian), *Ramnus* sp. (buckthorn), and *Vitis* sp. (wild grape).

A third, and final sampling, was initiated on the switchgrass, willow and corn plots in October 1998. Soil sampling from 0 to 60 cm was conducted, adhering to the same methodology as used in 1996, except that instead of 6 subsamples obtained from the willow and corn plots, only 4 were obtained, with no loss in the resulting accuracy of soil carbon determination. Soil samples were not obtained from the abandoned fields, or from the forest site.

Aboveground biomass sampling was also carried out in 1998 to determine productivity (4 samples in each plot) using the same methodology as in 1996 and 1997, however no litter,

weed biomass, or belowground biomass was sampled. Tissue samples were not analyzed for carbon content either.

3.1.2. Modified Mebius Procedure to Determine Carbon Concentration in 1996

The plant and soil samples were ground to pass a 100 mesh sieve, and analyzed for organic carbon content using a modified Mebius procedure, involving the digestion of each sample with an acidified dichromate solution (Yeomans and Bremner, 1988). A full description of this procedure is outlined in Zan (1998).

3.1.3. LECO Combustion Process to Determine Soil Carbon Concentration in 1998

In 1998, the soil samples were sent to the University of Guelph for analysis. A LECO 1400 C carbon analyzer was used to determine total soil carbon and soil organic carbon. Since this methodology varied from the Modified Mebius processes deployed in 1996, 60 of the stored and dried samples from 1996 (equally representing the 3 cropping systems and all 4 depths), were re-analyzed using a LECO method. A regression equation was derived ($r^2=0.99$) from the 60 re-analyzed samples, and their corresponding 1998 samples. From this equation, 1996 carbon values were adjusted to the 1998 values, to enable comparisons between the years.

All soil samples were stored in air-tight plastic bags immediately after sampling, and stored at approximately 10°C. Four to six weeks later, a subsample from each bag was placed in plastic, air tight vials and shipped to the University of Guelph, where they were analyzed for total and organic carbon by a LECO 1400 C carbon analyzer.

3.1.4. Calculation of Soil Profile Carbon on a Constant Mass Basis

When comparing different cropping systems (corn, switchgrass, and SRF willows), expressing soil carbon storage in terms of the concentration of carbon (% carbon) obtained from laboratory analyses, does not take into account the bulk density nor the thickness of the soil layers. Hence, the percent carbon does not account for differences in soil masses under different management systems. Therefore, all results were standardized to an equivalent soil mass of 7090 od Mg/ha in 1996, and 6910 odMg/ha in 1998, as outlined by Ellert and Bettany (1995).

3.1.5. Statistical Analyses

Data obtained for aboveground biomass, roots, and soil carbon were expressed on an oven dried mass per area basis (odMg/ha). Corn, switchgrass, and willow data were analyzed as a

randomized complete block design, with the 3 crops as fixed treatments, in each of 4 randomized blocks, and 2 sites as main factors. Corn and willow were sampled 6 times per plot in 1996 and 1997, and 4 times in 1998, whereas switchgrass was sampled 4 times per plot every year.

Statistical analyses were performed using SAS (SAS Institute, 1994). A probability level of $P \leq 0.05$ was considered significant. Data obtained for aboveground biomass and carbon were analyzed as analyses of variance (GLM procedure). Data obtained for root biomass and soil carbon were further analyzed as repeated measures analyses of variance, using depth as a repeated factor. Following significant ANOVA results, means were compared using the Student-Newman-Keuls (SNK) multiple range test. All analyses used plot means rather than subsample means.

3.2. Results

3.2.1. Aboveground Plant Yield and Carbon Content

3.2.1.1. Switchgrass

The average total aboveground yields for 1996 and 1997 were 15,879 kg/ha at the Seedfarm, and 16,314 kg/ha at the Ecomuseum (Table 3.1). In 1998, the standing biomass of switchgrass was 12,657 kg/ha at the Seedfarm and 12,931 kg/ha at the Ecomuseum. For individual years, there were no significant yield differences between the sites. In 1997, switchgrass aboveground yields increased by 1,157 kg/ha at the Seedfarm site, and 811 kg/ha at the Ecomuseum site, compared to 1996. The standing yields obtained in 1998 represent an average decrease of 917 kg/ha from 1996, and an average decrease of 1,309 kg/ha compared to 1997. The 1998 yields were found to be significantly lower than the 1996 and the 1997 yields. One contributing factor to lower yields in 1998 may have been the relatively low rates of N fertilizer applied (50 kg/ha/yr), which may have been insufficient to sustain higher yields than those obtained, after 5 years of growth.

Table 3.1. Switchgrass aboveground biomass (od kg/ha) and carbon content (kg/ha) for 1996 -1998 at the Seedfarm (SF) and Ecomuseum (ECO) sites.									
Site	1996				1997				1998
	Standing	Litter	Weed	TOTAL	Standing	Litter	Weed	TOTAL	Standing
Biomass Yield (kg/ha)									
SF	12883	2417 a	0	15300	14002	2455	0	16457	12657
ECO	14538	1371 b	0	15909	14203	2517	0	16720	12931
Mean	13711	1894	0	15605	14103	2486	0	16589	12794
Carbon Content (kg/ha)									
SF	5350	1123 a	0	6473	5844	1139	0	6983	-
ECO	6305	694 b	0	6999	6167	1272	0	7438	-
Mean	5828	909	0	6736	6006	1206	0	7211	-

Source: Zan (1998).

-, not measured

Means with different letters are significantly different at the 0.05 level according to the SNK test.

In 1996, switchgrass litter (consisting of dead plant residue) biomass yield and carbon content at the Seedfarm were significantly greater than at the Ecomuseum. Switchgrass aboveground carbon content in 1996 was 6,473 kg/ha and 6,999 kg/ha at the Seedfarm and Ecomuseum sites, respectively, compared to 6,983 kg/ha and 7,438 kg/ha in 1997 (Table 3.1). There were no significant differences between the sites. In 1997, switchgrass aboveground carbon increased by 8% and 6%, at the Seedfarm and Ecomuseum sites, respectively, compared to 1996. In 1996, at the Seedfarm site, the standing component of switchgrass contributed, on

average, 83% to aboveground organic carbon storage, and the litter component contributed 17%. At the Ecomuseum site, a greater contribution came from the standing component (90%), and less from the litter (10%). In 1997, the differences between the two sites had disappeared, with the standing component contributing approximately 84% and litter contributing to 16% of the aboveground carbon storage at both sites.

3.2.1.2. Willow

The aboveground willow samples obtained in 1997 and 1998 included the previous year's growth. Therefore, each previous year's yields were subtracted from the biomass sampled in the present year, to obtain the net annual growth. From Table 3.2 the average 1996 and 1997 total aboveground yields were calculated to be 13,363 kg/ha at the Seedfarm site and 19,159 kg/ha at the Ecomuseum site, with significantly higher yields at the latter site (statistical results not shown). In 1997, there was a 51% and 35% biomass increase at the Seedfarm and Ecomuseum sites, respectively, from 1996 yields.

In 1998, aboveground shoot biomass was measured, and found to represent an annual yield increment of 20,228 kg/ha at the Seedfarm, and 12,419 kg/ha at the Ecomuseum. This represents an 82% increase in shoot biomass from 1997 at the Seedfarm, and a 10% decrease from 1997 at the Ecomuseum. In spite of the site discrepancies, no significant difference in yield was found between the sites in 1998. High variances were found at both sites ($\pm 6,688$ kg/ha at the Seedfarm and $\pm 4,874$ kg/ha at the Ecomuseum), which may have masked any site effect. In addition, the 1998 yields did not differ significantly from the 1996 or the 1997 shoot yields.

Table 3.2. Willow aboveground biomass (od kg/ha) and carbon content (kg/ha) for 1996 -1998 at the Seedfarm (SF) and Ecomuseum (ECO) sites.												
Site	1996					1997					1998	
	Leaf	Shoot	Litter	Weed	TOTAL	Leaf	Shoot	Litter	Weed	TOTAL	Leaf	Shoot
Biomass Yield (kg/ha)												
SF	1171 a	7662 b	819 b	1012	10664 b	2397 a	11098	1613 b	955 b	16062	3742	20228
ECO	705 b	12054 a	2280 a	1250	16289 a	3260 a	13827	2420 a	2523 a	22028	1838	12419
Mean	938	9858	1550	1131	13477	2829	12463	2017	1739	19045	2790	16324
Carbon Content (kg/ha)												
SF	525 a	3657 b	378 b	433	4994 b	1058 b	5328	727 b	407 b	7520	-	-
ECO	330 b	5803 a	1006 a	541	7679 a	1530 a	6732	1064 a	1107 a	10433	-	-
Mean	428	4730	692	487	6337	1294	6030	896	757	8977	-	-

Source: Zan (1998).

-, not measured

Note: Total aboveground yields include weed biomass. Means with different letters are significantly different at the 0.05 level according to the SNK test.

The organic carbon content of willow aboveground material for 1996 was found to be significantly lower at the Seedfarm site (4994 kg/ha) compared with the Ecomuseum site (7679 kg/ha) (Table 3.2). Carbon contents from the 1997 biomass production were not significantly different; 7,520 kg/ha and 10,433 kg/ha at the Seedfarm and Ecomuseum sites, respectively. Willow aboveground carbon content in 1997 increased by 51% at the Seedfarm, and 36%, at the Ecomuseum site, from 1996.

Over 1996 and 1997, at the Seedfarm site, shoot, leaf, litter and weed components contributed an average of 72%, 13%, 8%, and 7%, respectively to the annual aboveground organic carbon storage. Results obtained at the Ecomuseum represented an average contribution of 69% from shoots, 10% from leaves, 11% from litter, and 9% from weeds.

3.2.1.3. Corn

Corn produced significantly more total aboveground biomass in 1996 than in 1997 at both sites (statistical results not shown). The average total aboveground biomass for 1997 was 24% and 16% lower than the biomass levels sampled in 1996 for the Seedfarm and Ecomuseum sites, respectively. Average total corn aboveground biomass over both years at the Seedfarm and Ecomuseum sites was 14,227 kg/ha and 14,927 kg/ha, respectively.

In 1998, corn aboveground biomass (excluding weeds) was 20,653 kg/ha at the Seedfarm and 18,956 kg/ha at the Ecomuseum. No significant site difference was found. The 1998 corn total yields (stalk/leaf, grain, and cob) were significantly higher than in either 1996 or in 1997. The average aboveground biomass for 1998 was 68% higher than in 1997 at the Seedfarm and 39% higher than in 1997 at the Ecomuseum.

Table 3.3. Corn aboveground biomass (od kg/ha) and Carbon content (kg/ha) for 1996 -1998 at the Seedfarm (SF) and Ecomuseum (ECO) sites.													
Site	1996					1997					1998		
	Stalk/ Leaf	Grain	Cob	Weed	TOTAL	Stalk/ Leaf	Grain	Cob	Weed	TOTAL	Stalk/ Leaf	Grain	Cob
Biomass Yield (od kg/ha)													
<i>SF</i>	7025	7664	1455	0	16144	6569	4834 a	906 a	0 b	12309	9134a	9732	1787
ECO	7254	7616	1386	0	16256	6933	3159 b	597 b	2909a	13598	7714b	9506	1736
Mean	7140	7640	1421	0	16200	6751	3997	752	1455	12954	8424	9619	1762
Carbon content (kg/ha)													
<i>SF</i>	3149	3242	655	0	7046	2956	2043 a	408 a	0 b	5406	-	-	-
ECO	3261	3401	624	0	7285	3135	1358 b	269 b	1309a	6071	-	-	-
Mean	3205	3322	640	0	7166	3046	1701	339	655	5739	-	-	-

Source: Zan (1998).

-, not measured

Means with different letters are significantly different at the 0.05 level according to the SNK test.

Due to greater corn aboveground yields in the first field season (1996), organic carbon analyses of aboveground plant material was significantly higher for corn in 1996 than in 1997. On average for both years, corn at the Seedfarm and Ecomuseum sites stored 6,226 kg/ha and 6,678 kg/ha of carbon, respectively (Table 3.3).

In 1996, at the Seedfarm site, the stalk/leaf and grain components contributed an average of 45% and 46%, respectively, to aboveground organic carbon storage. Similar results were obtained at the Ecomuseum, with percent contributions from stalk/leaf and grain of 45% and 47%, respectively. In 1997, however, the stalk/leaf component contributed 55% and 52% to the aboveground carbon storage at the Seedfarm and Ecomuseum sites, respectively. The grain portion contributed to 38% and 22% of total aboveground organic carbon for the Seedfarm and Ecomuseum sites, respectively. At the Ecomuseum site, there was a fairly large carbon contribution from weeds (22%).

3.2.1.4. Comparing the Ecosystems

3.2.1.4.1. Biomass Yields

At the Seedfarm, in 1996, corn and switchgrass produced significantly higher aboveground yields than willow (16,144 kg/ha, 15,300 kg/ha, and 10,664 kg/ha, respectively) (Figure 3.3). On the other hand, there were no significant differences found between any of the crops at the Ecomuseum site, with corn, switchgrass, and willow yields averaging 16,256 kg/ha, 15,909 kg/ha, and 16,290 kg/ha, respectively (Figure 3.3).

In 1997, at the Seedfarm site, switchgrass and willow had significantly greater aboveground annual yields than corn (16,457 kg/ha, 16,062 kg/ha, and 12,309 kg/ha, respectively). At the Ecomuseum site, willow had significantly greater (22,028 kg/ha) yields than corn (13,598 kg/ha). Switchgrass yields (16,720 kg/ha) were not significantly different from either willow or corn (Figure 3.3).

In 1998 at the Seedfarm, switchgrass, willow, and corn did not produce significantly different total aboveground yields (12,657 kg/ha, 22,950 kg/ha, and 20,653 kg/ha, respectively). At the Ecomuseum, no significant difference in aboveground biomass was observed either between switchgrass (12,931 kg/ha), willow (13,385 kg/ha) or corn (18,965 kg/ha). Corn had the highest aboveground yields in 1998 at both sites, however they were not significantly different from the willow or the switchgrass yields (Figure 3.4). This is partly attributed to the different corn varieties planted each year, as well as to the exceptional early growing season experienced in 1998. As well, willow total biomass was high and was very variable in 1998, with standard errors of $\pm 6,688$ kg/ha at the Seedfarm, and $\pm 4,874$ kg/ha at the Ecomuseum (Figure 3.4).

By drawing comparisons between the three individual cropping system yields (combining the data from both sites) between 1996, 1997 and 1998, it was found that switchgrass in 1998 produced significantly lower yields than in the two previous years. This decrease in yield after the fifth year is not normally expected for a warm season perennial grass system, and therefore may have been attributed to relatively low rates of fertilizer application. The willow aboveground shoot biomass in 1998 was not significantly different than in 1996 or in 1997. However, the corn total aboveground biomass (stalk/leaves, grain, and cobs) was significantly higher in 1998, compared with 1996 and with 1997.

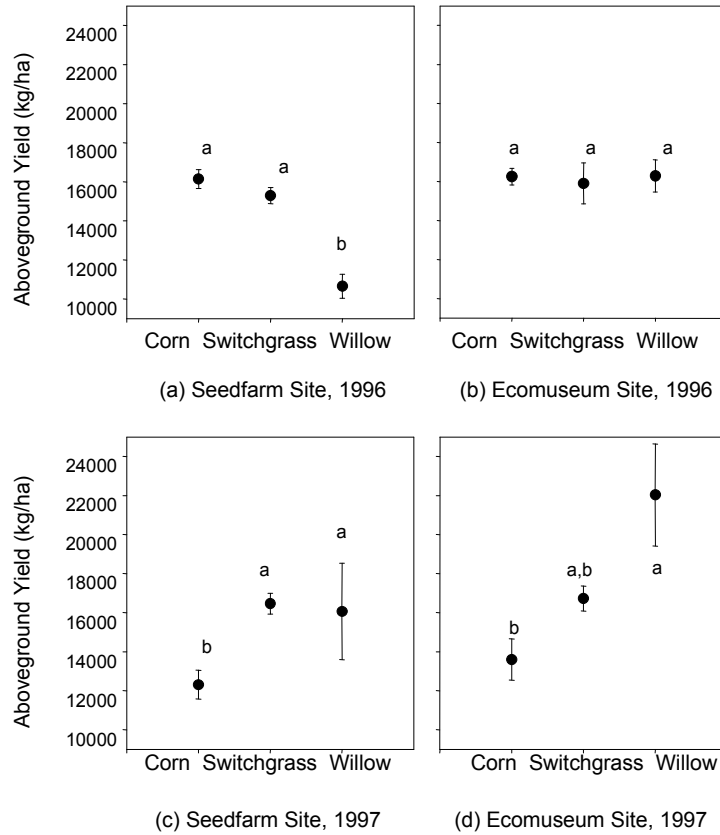

Source: Zan (1998)

Figure 3.3. Mean aboveground yield of corn, switchgrass, and willow at the Seedfarm, and Ecomuseum sites, at the end of the 1996 and 1997 growing seasons. Means with different letters are significantly different at the 0.05 level according to SNK test. Error bars represent standard error of the mean.

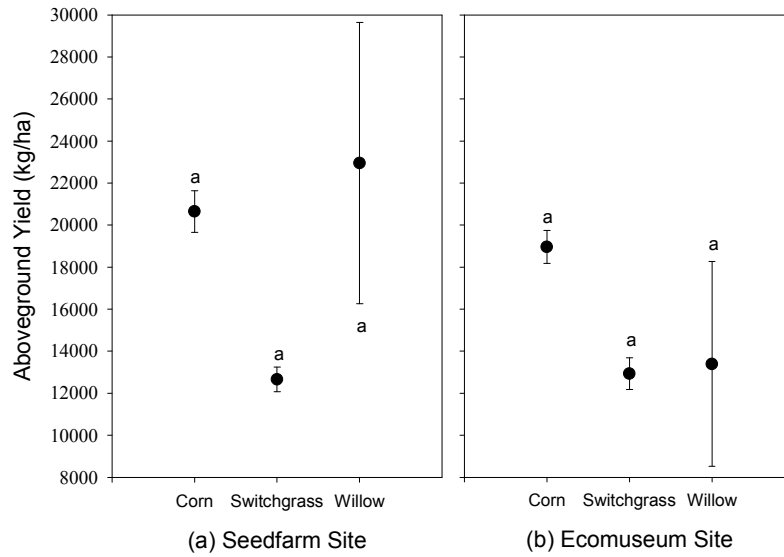
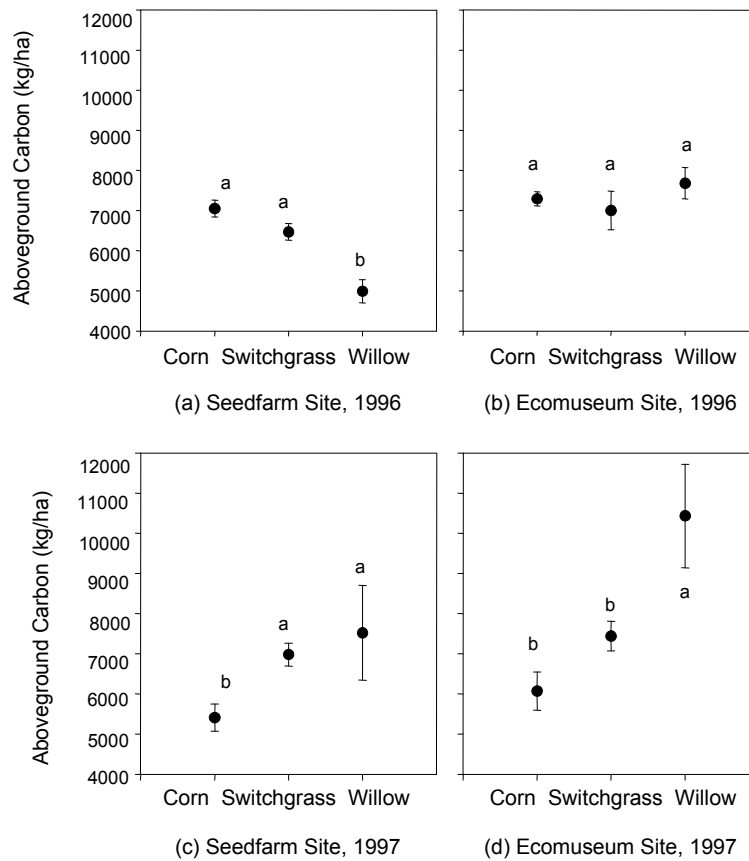

Figure 3. 4. Mean aboveground yield (excluding weeds and litter) of corn, switchgrass and willow at the Seedfarm and Ecomuseum sites, at the end of the 1998 growing season. Means with different letters are significantly different at the 0.05 level, according to the SNK test. Error bars represent standard errors of the means.

3.2.1.4.2. Carbon Concentrations

At the Seedfarm site, at the end of the 1996 growing season, corn and switchgrass accumulated significantly more organic carbon in their aboveground biomass than willow (7,046 kg/ha, 6,473 kg/ha, and 4,994 kg/ha, respectively). On the other hand, there were no significant differences found between any of the crops at the Ecomuseum site, with corn, switchgrass, and willow carbon contents averaging 7,285 kg/ha, 6,999 kg/ha, and 7,679 kg/ha, respectively (Figure 3.5).



Source: Zan (1998)

Figure 3.5. Mean aboveground carbon content of corn, switchgrass, and willow at the Seedfarm and Ecomuseum sites, at the end of the 1996 and 1997 growing season. Means with different letters are significantly different at the 0.05 level according to the SNK test. Error bars represent standard errors of the means.

In 1997, at the Seedfarm site carbon in the aboveground biomass produced by willow and switchgrass was significantly higher than in corn (7,520 kg/ha, 6,983 kg/ha, and 5,406 kg/ha, respectively). At the Ecomuseum site during the same year, willow aboveground carbon content (10,433 kg/ha) was significantly greater than the carbon content of switchgrass (7,438 kg/ha) and corn (6,071 kg/ha) (Figure 3.4).

In terms of the plant percent carbon content, willow had a significantly higher carbon concentration in its aboveground biomass than switchgrass at the Seedfarm site. No differences were found between any of the crops at the Ecomuseum (Table 3.4).

Site	Plantation	Aboveground
		% Carbon
Seedfarm	Corn	44.3 a,b
	Switchgrass	43.9 b
	Willow	45.3 a
Ecomuseum	Corn	45.0 a
	Switchgrass	46.5 a
	Willow	45.8 a

Source: Zan (1998).

Means with different letters are significantly different at the 0.05 level according to the SNK test.

3.2.2. Belowground Plant Yields and Carbon Content

3.2.2.1. Switchgrass

Since switchgrass lacks a root crown, all the roots were considered to be fine roots. The total root production as measured in 1996 was significantly greater at the Seedfarm site (8,068 kg/ha) than at the Ecomuseum site (5,965 kg/ha) (Table 3.5).

Site	Fine Roots				Total
	0-15	15-30	30-45	45-60±	
Root Biomass (od kg/ha)					
SF	4251 a	1931	954	932	8068 a
ECO	2776 b	1544	859	786	5965 b
Mean	3514	1738	907	859	7017
Carbon Sequestered (kg/ha)					
SF	1991 a	905	426	402	3723 a
ECO	1157 b	690	378	349	2574 b
Mean	1574	798	402	376	3149

Source: Zan (1998).

Means with different letters are significantly different at the 0.05 level according to the SNK test.

The total root carbon was significantly greater at the Seedfarm site (3,723 kg/ha) than at the Ecomuseum site (2,574 kg/ha). At the Seedfarm, the contribution to total root carbon storage at the 0-15, 15-30, 30-45, and 45-60 cm depth intervals were 53%, 24%, 11%, and 11%, respectively. At the Ecomuseum, the distribution was 45%, 27%, 15%, and 14%, respectively. It appears the more impervious layers of soils at the Seedfarm site confined most of the switchgrass roots to the surface horizons.

3.2.2.2. Willow

The roots of willow, as well as those of corn were comprised of the root crown, and the fine roots. In 1996, there were no significant differences in terms of fine and total root production in the 2 sites (Table 3.6). Fine root distribution up to 60 cm, at intervals of 15 cm, followed a ratio of approximately 8:9:1:1, at the Seedfarm site and of 28:18:4:1 at the Ecomuseum site.

Table 3.6. Willow root production and Carbon sequestered at the Seedfarm (SF) and Ecomuseum (ECO) sites, at the end of the 1996 growing season.							
Site	Fine Roots				Fine Roots	Root Crown	Total Roots
	0-15	15-30	30-45	45-60±			
Root Biomass (od kg/ha)							
SF	2285	2521	367	331 a	5506	3340	8845
ECO	3159	1969	405	110 b	5643	3431	9074
Mean	2722	2245	386	221	5575	3386	8960
Carbon Sequestered (kg/ha)							
SF	969	1021	152	127 a	2270	1516	3786
ECO	1152	779	160	46 b	2137	1562	3699
Mean	1061	900	156	86.5	2204	1539	3743

Source: Zan (1998).

Means of sites having different letters are significantly different at the 0.05 levels according to the SNK test.

There was no significant difference in fine root carbon between the Seedfarm (2,270 kg/ha) and Ecomuseum site (2,137 kg/ha). The percent contribution to root carbon storage by fine roots was 60% at the Seedfarm, and 58% at the Ecomuseum. There was also no significant difference between root crown carbon at the Ecomuseum (1,562 kg/ha) and at the Seedfarm (1,516 kg/ha). Root crown carbon storage was 40% and 42% of total root carbon at the Seedfarm and Ecomuseum sites, respectively. In total, there were no significant differences between total root carbon at the Seedfarm (3,786 kg/ha) and the Ecomuseum sites (3,699 kg/ha).

3.2.2.3. Corn

Corn fine root yields (Table 3.7) were significantly higher at the Seedfarm site (522 kg/ha) than at the Ecomuseum site (337 kg/ha). However, root crown yields were not significantly different at the Seedfarm site than at the Ecomuseum site. There were also no significant differences between total yields at both sites. The fine root distribution up to 60 cm, at intervals of 15 cm,

followed a ratio of approximately 4:4:1:1 at the Seedfarm site, and of 12:5:1:1 at the Ecomuseum site.

Site	Fine Roots				Fine Roots	Root Crown	Total Roots
	0-15	15-30	30-45	45-60±			
Root Biomass (od kg/ha)							
SF	216	203	53	50	522 a	1177	1699
ECO	203	91	23	20	337 b	1210	1547
Mean	210	147	38	35	430	1194	1623
Carbon Sequestered (kg/ha)							
SF	58	75	19	17	170 a	525	695
ECO	61	28	9	7	105 b	529	634
Mean	60	52	14	12	138	527	665

Source: Zan (1998).

Means with different letters are significantly different at the 0.05 level according to the SNK test.

Fine root carbon (Table 3.7) was significantly higher at the Seedfarm site (170 kg/ha) than at the Ecomuseum site (105 kg/ha). Percent fine root contribution to carbon storage was 24% and 17% at the Seedfarm and Ecomuseum sites, respectively. Root crown carbon was not significantly different between the Ecomuseum site (529 kg/ha) and the Seedfarm site (525 kg/ha), which represented 76% and 83% of belowground carbon storage for the Seedfarm and Ecomuseum site, respectively.

3.2.2.4. Abandoned Field and Forest

At 0-60 cm, using a soil mass of 7,090 od t/ha, an average root yield of 13,058 kg/ha was obtained for both abandoned fields. The distribution of fine roots was concentrated in the top 15 cm of the soil profile, with 81% of the roots located in this area. The lower layers (15-30, 30-45, and 45-60 cm) contained 12%, 5%, and 2% of the total roots in the depths, respectively. From the belowground biomass production, a root carbon content of 45% was assumed, to calculate root carbon sequestering.

For the forest ecosystem, an average fine root yield of 12,315 kg/ha was sampled. Total root production was nonetheless estimated based on studies conducted in Ohio under similar late secondary growth deciduous forest.

3.2.2.5. Comparing the Ecosystems

3.2.2.5.1. Root Biomass

At both sites, switchgrass and willow had significantly higher root yields than corn (Figure 3.6). When comparing switchgrass with willow, there was no significant difference in root production between the systems, except for switchgrass at the Ecomuseum site, which had a significantly lower root yield. Detailed comparisons including the root production measured in the abandoned fields, and the estimates for the hardwood forest, are presented in Zan (1998).

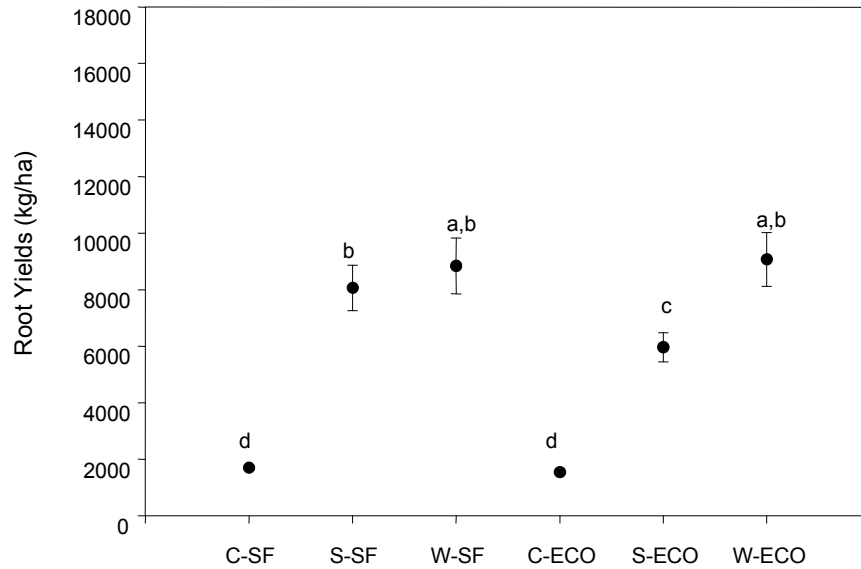

Source: Zan (1998)

Figure 3.6. Mean 1996 root yields for corn, switchgrass, and willow. Error bars represent standard errors of the mean. Means are significantly different at the 0.05 level according to the SNK test.

C=corn; S=switchgrass; W=willow; SF=Seedfarm; ECO=Ecomuseum.

Statistical analyses were performed on mean fine root production, for each of 4 sampling depths: 0-15, 15-30, 30-45, and 45-60 cm (Figure 3.7). At 0-30 cm, there were no significant differences between switchgrass and willow at either site, and corn had significantly lower fine root biomass than all other systems. At 30-45 cm, switchgrass at both sites produced significantly more roots than either the willow or the corn. At 45-60 cm, switchgrass at both sites had a significantly greater root yield than all other systems (Figure 3.7).

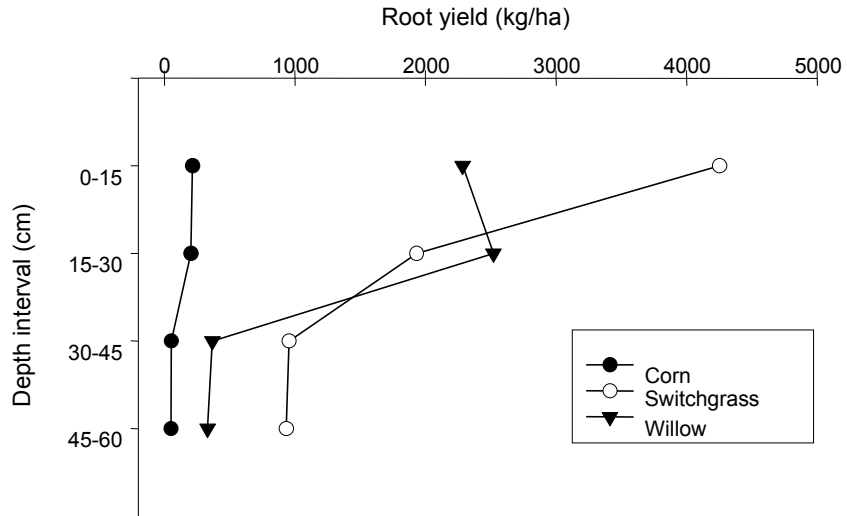

(a) Seedfarm Site

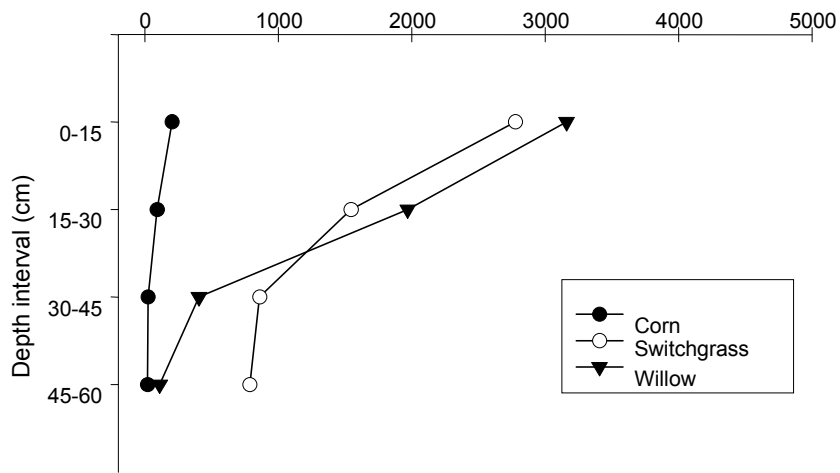

(b) Ecomuseum Site

Source: Zan (1998)

Figure 3.7. Mean fine root yields of corn, switchgrass, and willow, at the Seedfarm and Ecomuseum sites, at various depth intervals. Data only includes roots sampled with soil cores (no root crowns).

Overall, switchgrass had relatively low root biomass levels of 6-8 odMg/ha in these southwestern Quebec sites compared to other studies. In Virginia, Parish et al. (1990) found switchgrass root yields of 10.5 odMg/ha on average on three soils. As well, 14.5 –19.0 Mg/ha (Dahlman and Kucera, 1965) and 15.1 – 17.9 Mg/ha (Weaver and Zink, 1946) have been reported from the US Midwest. The relatively low root yields in the current study may be a result of several factors. One may be that switchgrass needs several more years to establish its root system fully in a more northerly location. Another may be that the favorable water conditions in the study region result in a relatively low investment in root biomass production compared with regions such as the US Midwest, which have lower rainfall to evaporation ratios. Finally, the soils were relatively shallow with compacted layers which inhibit rooting compared to deep prairie soils.

3.2.2.5.2. Root Carbon Sequestered

Comparisons of total root carbon at the Seedfarm site demonstrated that to an average sampling depth of 60 cm, both willow and switchgrass had significantly greater carbon accumulations than corn (3,786 kg/ha, 3,723 kg/ha, and 695 kg/ha, respectively). At the Ecomuseum site, willow root carbon was significantly greater than that of switchgrass, which was significantly higher than that of corn (3,699 kg/ha, 2,574 kg/ha, and 634 kg/ha, respectively) (Figure 3.8).

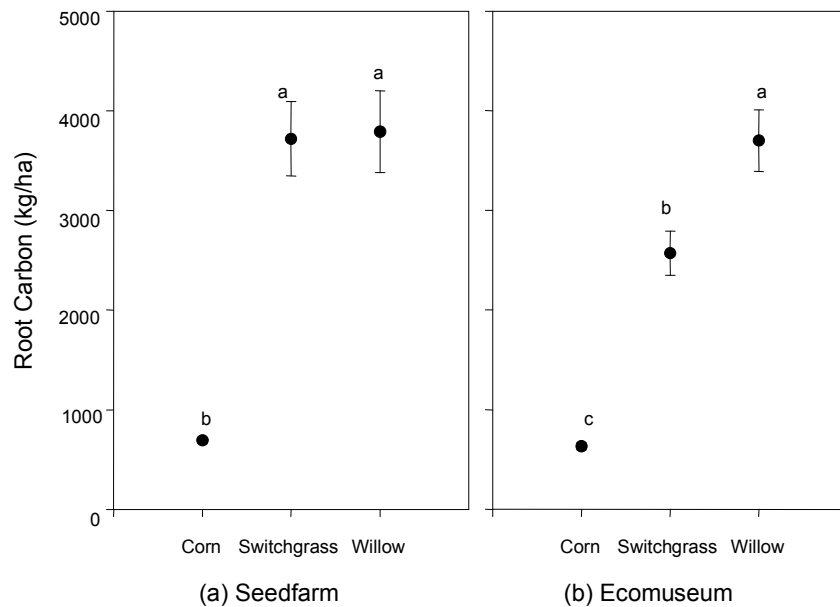

Source: Zan (1998)

Figure 3.8. Mean root carbon for corn, switchgrass, and willow at the Seedfarm and Ecomuseum sites at the end of the 1996 and 1997 growing seasons. Means with different letters are significantly different at the 0.05 level according to the SNK test. Error bars represent standard errors of the mean.

Figure 3.9 shows fine root carbon accumulations for each of the 4 sampling depths (0-15, 15-30, 30-45, and 45-60 cm). At the Seedfarm site, at a depth of 0-15 cm, switchgrass and SRF willow did not differ significantly in their fine root carbon content (1,991 kg/ha and 969 kg/ha, respectively). Both had significantly greater root carbon than corn (58 kg/ha). At the Ecomuseum site, both switchgrass and willow accumulated significantly more carbon than corn (1,157 kg/ha, 1,152 kg/ha, and 61 kg/ha, respectively).

At the 15-30 cm depth, a similar trend was observed at both sites. Switchgrass (Seedfarm: 905 kg/ha; Ecomuseum: 691 kg/ha) and willow (Seedfarm: 1,021 kg/ha; Ecomuseum: 779 kg/ha) had significantly more stored carbon than corn (Seedfarm: 75 kg/ha; Ecomuseum: 28 kg/ha).

At 30-45 cm, results differed from the 2 previous depth intervals, with switchgrass having significantly higher carbon accumulations (Seedfarm: 426 kg/ha; Ecomuseum: 378 kg/ha) than willow (Seedfarm: 152 kg/ha; Ecomuseum: 160 kg/ha) and corn (Seedfarm: 19 kg/ha; Ecomuseum: 9 kg/ha) at both sites. The same applied at 45-60 cm, switchgrass (Seedfarm: 347

kg/ha; Ecomuseum: 337 kg/ha) had significantly greater carbon than willow (Seedfarm: 100 kg/ha; Ecomuseum: 44 kg/ha) and corn (Seedfarm: 21 kg/ha; Ecomuseum: 5 kg/ha).

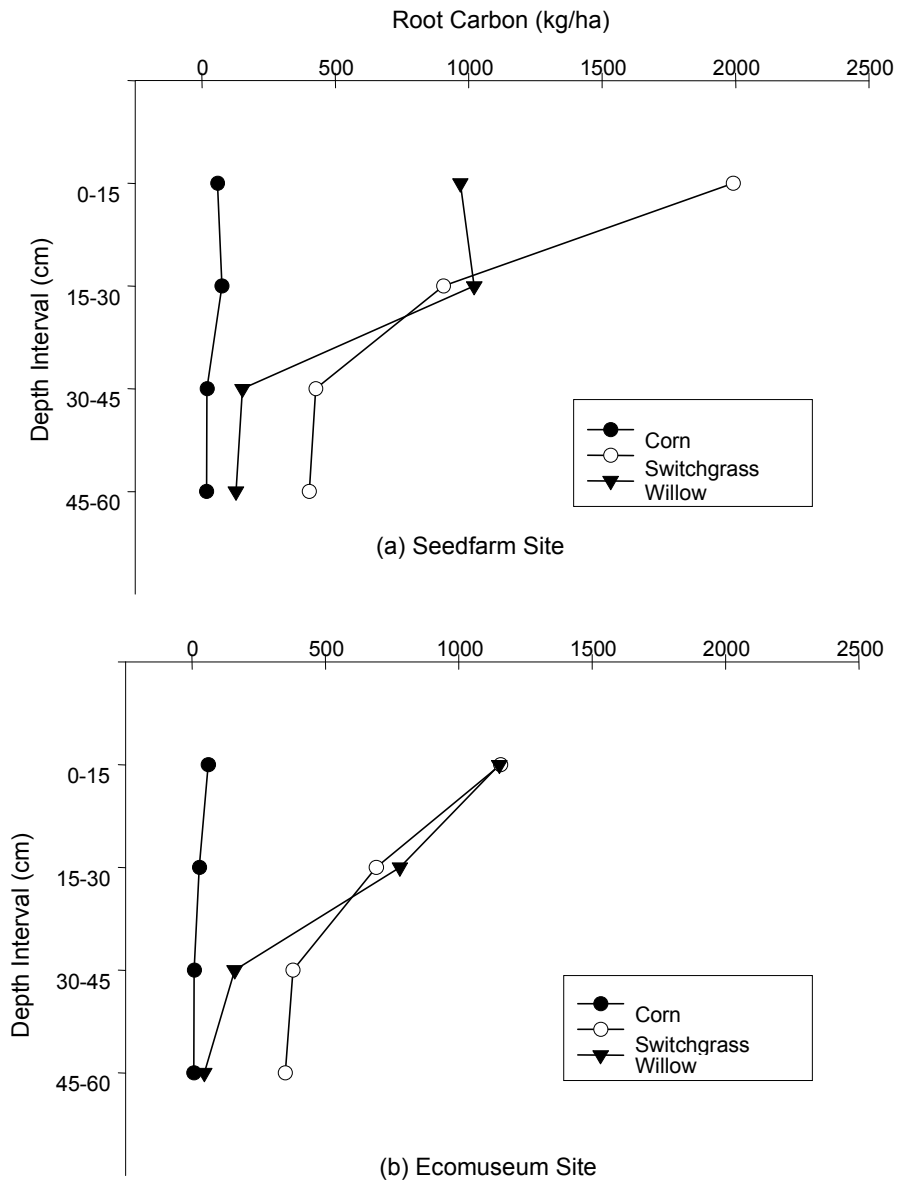

Source: Zan (1998)

Figure 3.9. Mean root carbon accumulations of corn, switchgrass, and willow, at the Seedfarm and the Ecomuseum sites, at various depth intervals. Data only includes roots sampled with soil cores (no root crowns).

Table 3.8 summarizes the concentration of root percent carbon content for the three cropping systems, which shows root carbon content to be significantly lower for corn at 0-15 cm at both sites. At 15-30 cm, switchgrass had the highest percent root C at the Seedfarm site. Willow had significantly lower root carbon than switchgrass, but more than corn. No differences were detected at the 30-45 cm level, at either site. At the Ecomuseum, at 45-60 cm, corn had significantly lower carbon concentration than switchgrass or willow.

Table 3.8. Average carbon content (%) of roots at 4 depth intervals (Seedfarm and Ecomuseum sites - 1996)						
Site	Plantation	Root				Crown
		0-15	15-30	30-45	45-60±	
Seedfarm	Corn	27.5 b	36.7 c	35.1	35.1	44.6
	Switchgrass	47.1 a	46.8 a	45.0	43.0	n.a.
	Willow	43.0 a	43.0 b	40.0	38.0	44.9
Ecomuseum	Corn	30.5 b	34.7	39.9	32.1 b	43.8
	Switchgrass	42.3 a	44.6	42.8	42.5 a	n.a.
	Willow	39.8 a	43.4	41.0	43.1 a	45.3

Source: Zan (1998).

Means with different letters within a site are significantly different at the 0.05 level according to the SNK test.

n.a., not applicable

3.2.3. Soil Carbon

Soil carbon measurements were made in 1996 and in 1998. A different soil organic carbon analysis was used for both years, hence the values in 1996 were adjusted, by using a regression equation, to the values in 1998. The values presented for 1996 (text and tables) have not been adjusted using a regression equation. However, when comparisons are drawn between 1996 and 1998, the 1996 soil organic carbon values were transformed. It is always stated when transformations on the 1996 data were conducted.

3.2.3.1. Switchgrass

On average, in 1996, there was significantly more organic carbon stored under switchgrass at the Ecomuseum site (123 t/ha) than at the Seedfarm site (99 t/ha). The vertical distribution of total soil organic carbon from 0-60 cm in the soil profile at 15 cm intervals, was 41%, 30%, 13%, and 16%, respectively for the Seedfarm site, and 39%, 37%, 15%, and 11%, respectively at the Ecomuseum site (Table 3.9).

In 1998, no significant difference between the sites was found; the Ecomuseum stored 90 t/ha, and the Seedfarm stored 77 t/ha. The vertical distribution of total organic carbon from 0-60 cm, at 15 cm intervals, was 38%, 29%, 13% and 19%, respectively at the Seedfarm, and 37%, 30%, 17%, and 17%, respectively at the Ecomuseum site (Table 3.10).

Table 3.9. Soil organic carbon levels measured in switchgrass at the Seedfarm (SF) and Ecomuseum (ECO) in October 1996						
Site	Block	Soil Carbon (t/ha)				
		0-15	15-30	30-45	45-60±	0-60±
SF	1	47	37	18	13	115
	2	36	29	14	19	98
	3	36.	21	9	19	85
	4	42	32	11	14	99
	Mean	40 b	30 b	13	16	99 b
ECO	1	57	57	24	12	149
	2	49	49	23	13	133
	3	39	39	15	21	115
	4	45	35	9	7	109
	Mean	48 a	45 a	18	16	126 a

Source: Zan (1998).

Means with different letters are significantly different at the 0.05 level according to the SNK test.

Table 3.10. Soil organic carbon levels measured in switchgrass at the Seedfarm (SF) and Ecomuseum (ECO) in October 1998						
Site	Block	Soil Carbon (t/ha)				
		0-15	15-30	30-45	45-60±	0-60±
SF	1	33	23	9	6	71
	2	29	21	10	13	73
	3	26	18	9	27	80
	4	29	26	13	16	84
	Mean	29	22	10	15	77
ECO	1	35	29	14	7	85
	2	33	30	19	11	93
	3	34	27	16	20	97
	4	31	23	11	22	87
	Mean	33	27	15	15	90

Means with different letters are significantly different at the 0.05 level according to the SNK test.

3.2.3.2. Willow

In 1996, there was significantly more carbon stored under willow at the Ecomuseum (147 t/ha) than at the Seedfarm site (110 t/ha). The vertical distribution of soil organic carbon from 0-60 cm, at 15 cm intervals was 35%, 35%, 19%, and 11%, respectively at the Ecomuseum, and 36%, 33%, 15%, and 17%, respectively at the Seedfarm site (Table 3.11).

Table 3.11. Soil organic carbon levels measured in SRF Willow at the Seedfarm (SF) and Ecomuseum (ECO) in October 1996						
Site	Plot	Soil Carbon (t/ha)				
		0-15	15-30	30-45	45-60±	0-60±
SF	1	39	35	16	17	108
	2	38	32	20	19	109
	3	43	40	18	20	121
	4	40	36	10	15	102
	Mean	40 b	36 b	16 b	18	110 b
ECO	5	50	46	26	11	133
	6	54	51	33	21	160
	7	48	49	21	17	134
	8	54	57	34	15	160
	Mean	52 a	51 a	28 a	16	147 a

Source: Zan (1998).

Means with different letters are significantly different at the 0.05 level according to the SNK test.

In 1998, no significant difference was found between the organic carbon storage at the Ecomuseum (98 t/ha) or at the Seedfarm (88 t/ha). The vertical distribution of soil organic carbon from 0-60 cm, at 15 cm depth intervals was 36%, 34%, 16%, and 13%, respectively at the Ecomuseum, and 38%, 31%, 16%, and 18%, respectively at the Seedfarm (Table 3.12).

Table 3.12. Soil organic carbon levels measured in SRF Willow at the Seedfarm (SF) and Ecomuseum (ECO) in October 1998						
Site	Block	Soil Carbon (t/ha)				
		0-15	15-30	30-45	45-60±	0-60±
SF	1	36	30	17	16	99
	2	37	25	10	15	87
	3	33	30	16	18	97
	4	26	22	12	13	73
	Mean	33	27	14	16	88
ECO	1	34	29	18	11	92
	2	32	34	17	15	98
	3	40	37	20	19	116
	4	35	29	11	9	84
	Mean	35	32	16	13	98

Means with different letters are significantly different at the 0.05 level according to the SNK test.

3.2.3.3. Corn

In 1996, there were no significant differences in soil carbon storage under corn between the Ecomuseum site (111 t/ha) and the Seedfarm site (116 t/ha) in 1996 (Table 3.13). The vertical distribution of soil organic carbon from 0-60 cm in the soil profile at the 15 cm intervals was 36%, 35%, 13%, and 16%, respectively for the Ecomuseum site, and 37%, 34%, 18%, and 11%, respectively for the Seedfarm site.

Table 3.13. Soil carbon levels measured in corn at the Seedfarm (SF) and Ecomuseum (ECO) in October 1996						
Site	Plot	Soil carbon (t/ha)				
		0-15	15-30	30-45	45-60±	0-60±
SF	1	44	43	32	11	131
	2	42	36	13	11	102
	3	39	37	16	19	111
	4	45	41	22	11	119
	Mean	42	39	21 a	13	116
ECO	5	41	37	13	23	114
	6	43	40	14	10	107
	7	37	35	16	23	112
	8	41	41	16	15	113
	Mean	40	38	15 b	18	111

Source: Zan (1998).

Means with different letters are significantly different at the 0.05 level according to the SNK test.

There was no site difference in 1998 between the amount of organic carbon stored at the Ecomuseum (83 t/ha) or at the Seedfarm (84 t/ha). The vertical distribution from 0-60 cm at 15 cm intervals, was 33%, 33%, 17% and 18%, respectively for the Ecomuseum, and 31%, 30%, 18%, and 23%, respectively at the Seedfarm (Table 3.14).

Table 3.14. Soil carbon levels measured in corn at the Seedfarm (SF) and Ecomuseum (ECO) in October 1998						
Site	Block	Soil carbon (t/ha)				
		0-15	15-30	30-45	45-60±	0-60±
SF	1	26	28	21	24	99
	2	24	25	10	8	67
	3	27	23	16	28	94
	4	27	22	13	15	77
	Mean	26	25	15	19	85
ECO	1	26	21	15	12	74
	2	27	29	12	10	78
	3	25	26	11	23	85
	4	30	34	20	14	98
	Mean	27	28	14	15	83

Means with different letters are significantly different at the 0.05 level according to the SNK test.

3.2.3.4. Abandoned Field and Forest

On average, 109 t/ha of carbon was sequestered from 0-60 cm in the abandoned field. The same amount, 109 t/ha was also sequestered under the forest system from 0-60 cm. Approximately 45 % of the carbon was sequestered at 0-15 cm in both systems. These soils

were not plowed in the past 25 years, therefore it would be expected that high C levels would be concentrated in the surface horizons. These measurements were only taken in 1997.

3.2.3.5. Comparing the Ecosystems

In 1996, at the Seedfarm, no significant differences were found between the cropping systems, whereas at the Ecomuseum, significant differences were observed; willow soil organic carbon content was significantly greater than switchgrass, which was greater than corn, with 147 t/ha, 126 t/ha, and 111 t/ha, respectively (Figure 3.10). In addition, the Ecomuseum overall, had significantly higher soil organic carbon than the Seedfarm (121 t/ha, compared to 101 t/ha, respectively). As no benchmark was established of carbon levels in 1993 when the original plots were established, it cannot be said with certainty whether the corn system represents original levels on the site. Nevertheless, the differences between the systems were significant within 1996.

In 1998, at both the Seedfarm and the Ecomuseum, no significant differences were found between the cropping systems. However, in 1998, similar to in 1996, the Ecomuseum demonstrated a significantly higher level of soil organic carbon compared to the Seedfarm (91 t/ha compared to 83 t/ha, respectively). When comparing the three cropping systems, at both sites, willow at the Ecomuseum had significantly higher soil organic carbon levels than switchgrass at the Seedfarm (Figure 3.11). The other cropping systems were not significantly different from each other. When averaging the data at both sites, willow had significantly higher soil organic carbon compared to switchgrass and corn (94 t/ha, 84 t/ha, and 83 t/ha, respectively). This was similar to the transformed 1996 soil organic carbon results (Table 3.15), where willow accumulated 122 t/ha, which was significantly higher than both switchgrass or corn (both of which had 106 t/ha).

<i>Table 3.15. 1996 soil organic carbon levels in four soil layers, for all cropping systems</i>						
Site	Crop	Soil organic carbon t/ha				± 0-60 cm
		0-15 cm	15-30 cm	30-45 cm	45-60 cm	
Seedfarm	Willow	38 c	34 c	15 bc	17	104 c
	Switchgrass	38 c	28 d	12 c	15	93 d
	Corn	39 c	37 c	20 b	12	108 c
Ecomuseum	Willow	49 a	48 a	26 a	15	138 a
	Switchgrass	45 b	42 b	17 bc	15	119 b
	Corn	38 c	36 c	14 bc	17	105 c

Means with different letters, within a column, are significantly different at the 0.05 level according to the SNK test.

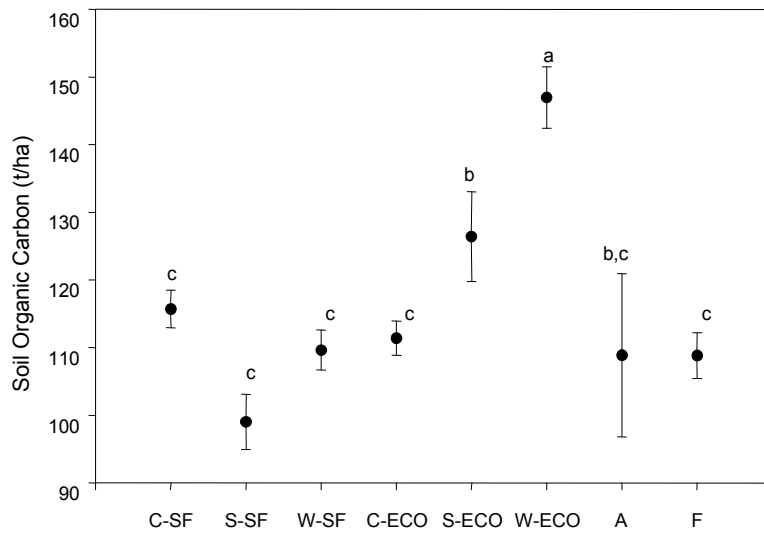

Source: Zan (1998)

Figure 3.10. Mean 1996 soil organic carbon in corn, switchgrass, willow, abandoned field, and forest, in an equivalent soil mass of 7090 t/ha. Error bars represent standard error. Means with different letters are significantly different from each other at the 0.05 level according to the SNK test.

C = corn; S = switchgrass; W = willow; A = abandoned field; F = forest; SF = Seedfarm, ECO = Ecomuseum

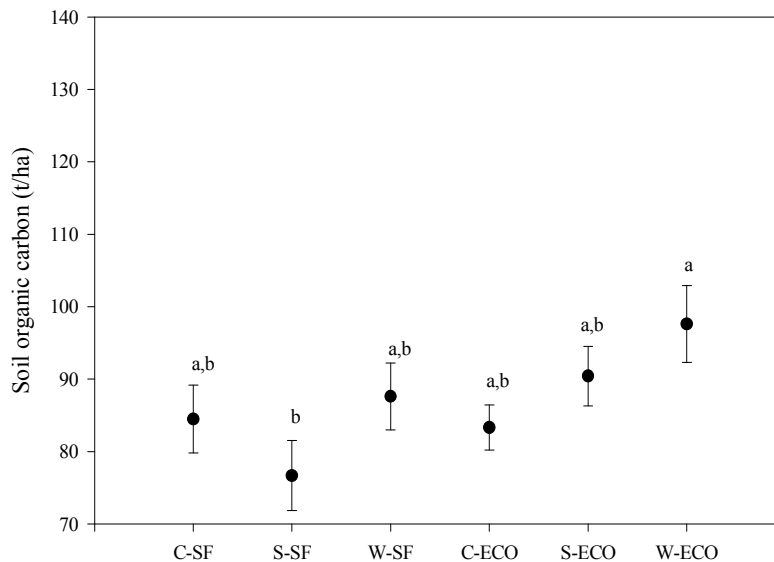

Figure 3.11. Mean 1998 soil organic carbon levels in corn, switchgrass and willow, in an equivalent soil mass of 6910 t/ha. Error bars represent standard error of the mean. Means with different letters are significantly different from each other at the 0.05 level according to the SNK test.

C = corn; S = switchgrass; W = willow; SF = Seedfarm, ECO = Ecomuseum

When examining the individual soil layers, significant organic carbon differences were found only at 0-30 cm depths (Table 3.16). From 0-15 cm depth, willow at the Ecomuseum had significantly higher organic carbon than corn at both sites, as well as switchgrass at the Seedfarm. At 15-30 cm depth, willow at the Ecomuseum had significantly higher soil carbon than corn and switchgrass at the Seedfarm. From 30-45 cm and from 45-60 cm no significant differences were found (Table 3.16).

Table 3.16. 1998 soil organic carbon levels in four soil layers, for all cropping systems

Site	Crop	Soil organic carbon t/ha				± 0-60 cm
		0-15 cm	15-30 cm	30-45 cm	45-60 cm	
Seedfarm	Willow	33 ab	27 ab	14	16	88 ab
	Switchgrass	29 bc	22 b	10	15	77 b
	Corn	26 c	25 b	15	19	85 ab
Ecomuseum	Willow	35 a	33 a	16	14	98 a
	Switchgrass	33 ab	27 ab	15	15	90 ab
	Corn	27 c	28 ab	14	15	83 ab

Means with different letters, within a column, are significantly different at the 0.05 level according to the SNK test.

By comparing the soil organic carbon values obtained in 1998 with the values from 1996 (after transforming the data by the regression equation: 1998 data = -0.086 + 0.942*[1996 data], $r^2=0.99$), the 1998 levels were found to be significantly lower. Average losses of soil carbon from both sites were 27%, 23%, and 29% for switchgrass, willow and corn, respectively in the 0-30 cm layer, while losses of 7%, 15% and 1% were experienced at 30-60 cm for switchgrass, willow and corn, respectively. This decrease in soil organic carbon was experienced in all treatments (Figure 3.12), and may have been a result of soil fertility levels not being maintained sufficiently high enough to meet the demands of the crops. Annual crops, which are nutrient demanding, such as corn, are well documented to steadily deplete soil fertility (Anderson et al., 1997; Dalal, 1989; Lindstrom, 1986). Perennial crops add litter and root biomass (Zan, 1998), enriching the soil as well as providing a permanent soil cover, preventing soil erosion. However, if soil nutrients are low, it is probable that high rates of mineralization from organic matter will take place, by micro organisms, mineralization can lead to a large and rapid loss of soil organic carbon from 0-30 cm (Hansen, 1993).

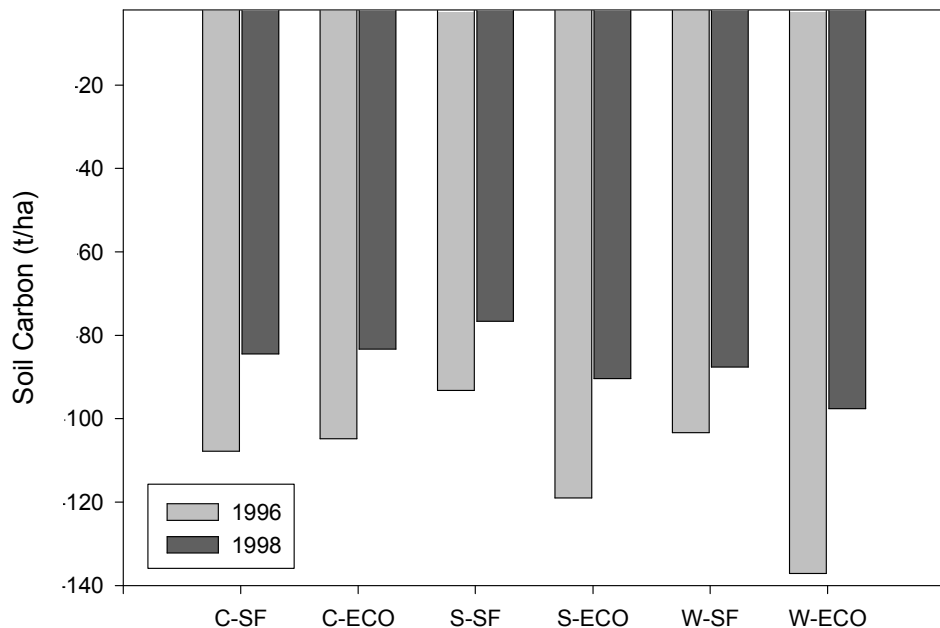

Figure 3.12. Comparison of soil organic carbon levels measured from 0-60 cm, in 1996 and 1998 in corn, switchgrass and willow at the Seedfarm and Ecomuseum sites. For statistical results, refer to Figures 3.10 and 3.11.

C = corn; S = switchgrass; W = willow; SF = Seedfarm site; ECO = Ecomuseum site

Numerous studies have demonstrated the beneficial effects of N application on soil organic carbon levels (Rasmussen and Albrecht, 1998; Singh et al., 1998; Solberg et al., 1998). Total soil nitrogen in 1998 was measured in the 0-15 cm depth of each plot (results not shown). A correlation between the amount of total N and total C in the soil was found ($r=0.66$). Therefore, N concentration in the 0-15 cm depth generally responds to management treatments in a similar manner as C; this was confirmed by a study conducted by Campbell et al. (1996). Furthermore, total N concentrations were found to be significantly higher in the willow plots, followed by the switchgrass, which had significantly more total N than the corn, at both the Ecomuseum and the Seedfarm sites. These results follow a similar trend as the soil carbon results, by willow having relatively high soil organic carbon concentrations at both sites.

Despite the decreases in organic carbon observed from 1996 to 1998, when comparing the 1998 willow and switchgrass systems with the 1998 corn systems, at both sites, carbon levels were higher, except in the switchgrass plots at the Seedfarm (Table 3.17). In 1998, from 0-60 cm, at the Ecomuseum, willow had 15 t/ha more organic carbon than corn, and switchgrass had

7 t/ha more. At the Seedfarm, willow systems had 4 t/ha more organic carbon than corn, compared to switchgrass, which had 7 t/ha less than in the corn systems.

If the 0-15 cm depth increment is examined only (Table 3.16), which is the most significant for organic carbon changes, willow was found to have 7 t/ha and 8 t/ha more organic carbon than the corn system, at the Seedfarm and the Ecomuseum, respectively. And switchgrass did not lose carbon, but was found to have 3 t/ha and 6 t/ha more organic carbon than the corn, at the Seedfarm and the Ecomuseum, respectively.

Table 3.17. Mean 1996 and 1998 soil organic carbon from 0-60 cm in each cropping system			
Site	Crop	1996 [†]	1998
		Organic Carbon (t/ha)	
Seedfarm	Willow	103	88 (-8)
	Switchgrass	93	77 (-8)
	Corn	108	85 (-12)*
	Mean	101 b	83 b (-9)
Ecomuseum	Willow	137	98 (-20)
	Switchgrass	119	90 (-14)
	Corn	105	83 (-11)
	Mean	121 a	91 a (-15)

Means with different letters, within a column, are significantly different at the 0.05 level according to the SNK test.

[†] 1996 values transformed with the regression equation $1998 = -0.086*[1996 \text{ data}] (r^2=0.99)$, to be able compare with 1998 values

() Values in brackets represent the amount of annual incremental organic C increase since the last sampling period (Mg C ha/yr)

3.2.3.6. Total Yield and Carbon in 1996

When comparing total biomass accumulation in all systems in 1996 (Figure 3.13), plant matter estimated for the 120 year old mature hardwood forest site (364 t/ha) was significantly higher than all other systems, followed by the abandoned field (28.6 t/ha) and willow at the Ecomuseum (28.2 t/ha). Switchgrass at the Ecomuseum (22.3 t/ha), switchgrass at the Seedfarm (24.0 t/ha), and willow at the Seedfarm (22.2 t/ha) did not differ significantly from each other. They were also all significantly more productive than corn at both the Seedfarm (15.9 t/ha) and the Ecomuseum (16.5 t/ha). It is difficult to get an estimate of the annual aboveground productivity of the forest, as no estimates of salvage harvesting are available. The old meadow consisted of both herbaceous material and light brush, which also represented several years of biomass accumulation.

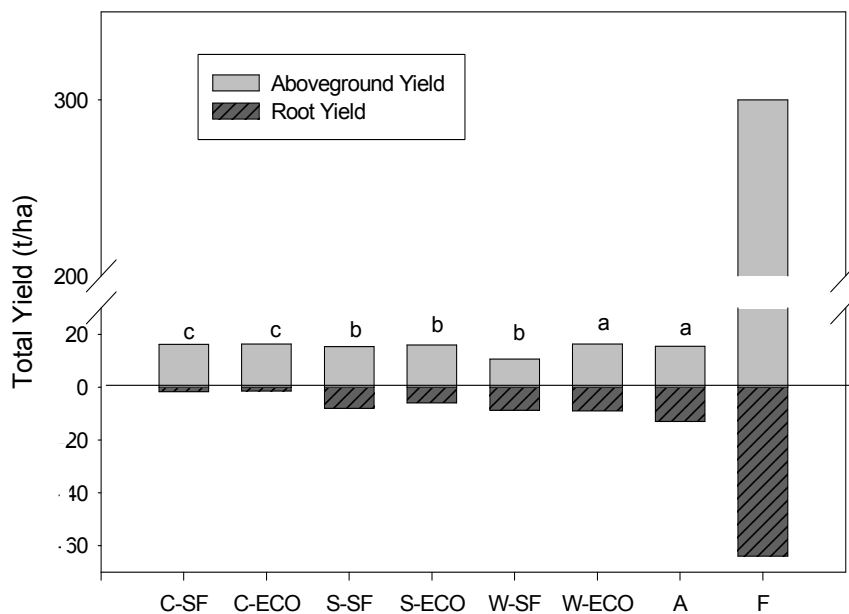

Source: Zan (1998)

Figure 3.13. Total plant biomass yield in 1996 for corn, switchgrass and willow, and 1997 plant biomass for abandoned field and forest. Means with different letters are significantly different at the 0.05 level, according to the SNK test. Note that forest and abandoned field aboveground and forest root data are estimated. Statistical tests did not include forest data.

C = corn; S = switchgrass; W = willow; A = abandoned field; F = forest; SF = Seedfarm site; ECO = Ecomuseum site

Similarly, in 1996, the forest had significantly more total (aboveground, belowground and soil) carbon stored (273 t/ha) than the other systems, followed by willow at the Ecomuseum site (161 t/ha). Switchgrass at the Ecomuseum (133 t/ha) also accumulated significantly more organic carbon than the remaining sites. Corn at both the Seedfarm (122 t/ha) and Ecomuseum (118 t/ha) sites, willow and switchgrass at the Seedfarm, as well as the abandoned field (122 t/ha) did not differ significantly in their total carbon levels (Figure 3.14).

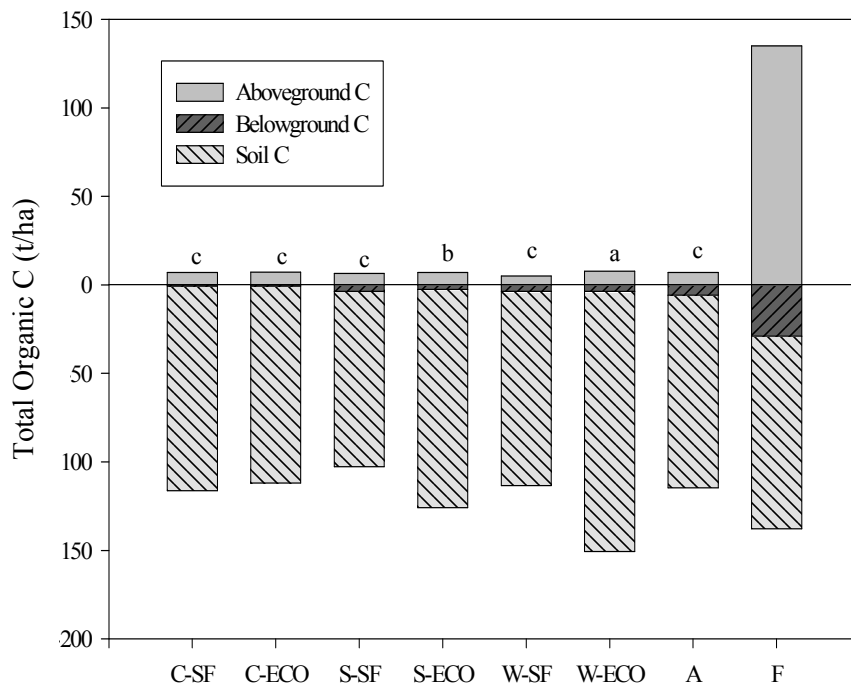

Source: Zan (1998)

Figure 3.14. Total organic carbon measured in 1996 in the plant biomass and soil for corn, switchgrass and willow, and total organic carbon measured in 1997 in the plant biomass and soil for abandoned field and forest. Means with different letters are statistically different at the 0.05 level according to the SNK test. Note that the forest and abandoned field aboveground and forest root data are estimated. Statistical data did not include forest data.

C = corn; S = switchgrass; W = willow; A = abandoned field; F = forest; SF = Seedfarm site; ECO = Ecomuseum site.

3.3. Discussion

The main objective of this research was to compare carbon storage in two perennial biomass energy plantations (SRF willow and switchgrass), to determine which was the most efficient at sequestering carbon in both the above- and belowground biomass, as well as in the soil. Site differences were observed, which are also discussed. When comparing aboveground, belowground, and soil carbon in cropping systems, the results obtained in 1996 are referred to, as this was the only year in which all three were measured. In 1998 soil organic carbon and aboveground biomass were measured. This is discussed after the 1996 results are presented.

The Ecomuseum site was more fertile than the Seedfarm, as it received regular additions of 20 Mg/ha/yr of solid dairy manure prior to 1993, whereas the Seedfarm did not. Therefore, C, N, P, and S levels were likely to be much higher at the Ecomuseum site, especially deeper in the soil profile (Rasmussen and Parton, 1994; Eghball et al., 1996). Increased levels of initial soil organic carbon at the Ecomuseum site were also highly probable due to the manure additions (Rasmussen and Parton, 1994). Soil benchmark carbon values were not taken in 1993. Instead, willow and switchgrass cropping systems were compared to corn (annual row crop), to determine annual amounts of carbon sequestration. However, it should be kept in mind that from 1993 to 1995 corn was not grown on any of the sites, and consequently, only influenced soil carbon levels when it was planted; prior to 1993, and from 1996 onwards (Appendix 1).

3.3.1. Plant Carbon in 1996

Aboveground carbon in switchgrass (leaf, shoot, stem, litter, and weeds) did not differ between the sites in 1996. However, there was significantly greater root production at the Seedfarm site, which led to a 45% increase in root carbon, compared to the Ecomuseum.

Perennial crops compared with annuals cropping systems have the potential to increase overall C storage by increasing belowground biomass, since the living root systems of perennials remain in the soil to support regeneration of aboveground material. This represents a continuous pool of stored C, which will increase soil organic matter levels as well.

In the current study, we were able to demonstrate that agricultural crops, such as corn, have very limited belowground biomass production, compared with short rotation trees and switchgrass. As well, this study showed that switchgrass has significantly greater root yields below 30 cm depth in comparison with a corn and willow crop, and below 45 cm in comparison

with a mature hardwood forest and 20-year-old abandoned field. Such grasses therefore have the potential for high C storage because of increased organic matter in deeper horizons over the long-term. Such perennial systems, if properly managed, may be excellent (additional) C sinks.

Nutrient-poor sites tend to have greater litter accumulations than nutrient-rich sites but less soil organic matter accumulation (Vogt et al., 1995). Plant material growing on nutrient-poor sites tends to be of poorer quality, containing greater lignin concentrations as well as other secondary chemicals (Vogt et al., 1995). This may explain why greater amounts of litter were found at the Seedfarm site. Increased lignin leads to a reduction in microorganisms responsible for the decomposition of these plant tissues, thus resulting in slower rates of soil organic matter formation.

Willow aboveground carbon was significantly higher at the Ecomuseum site than at the Seedfarm, respectively, while no significant differences were found in root carbon storage between the sites. The Ecomuseum site had 34% more soil organic carbon than the Seedfarm site in 1996. Soil fertility levels were expected to remain high at the Ecomuseum compared with the Seedfarm, even after 4 years. The larger additions of C inputs by willow leaves at the Ecomuseum along with the higher initial soil carbon level, caused by previous manure applications, may have also contributed to greater soil fertility at the Ecomuseum.

The average amounts of carbon in willow, switchgrass, and corn removed at the time of harvest, and the amounts of carbon input into the soil, as measured in 1996 are summarized in Figure 3.14. Most of the corn soil carbon input originated from the aboveground residues, whereas for SRF willows and switchgrass, most of the soil carbon input stemmed from the roots.

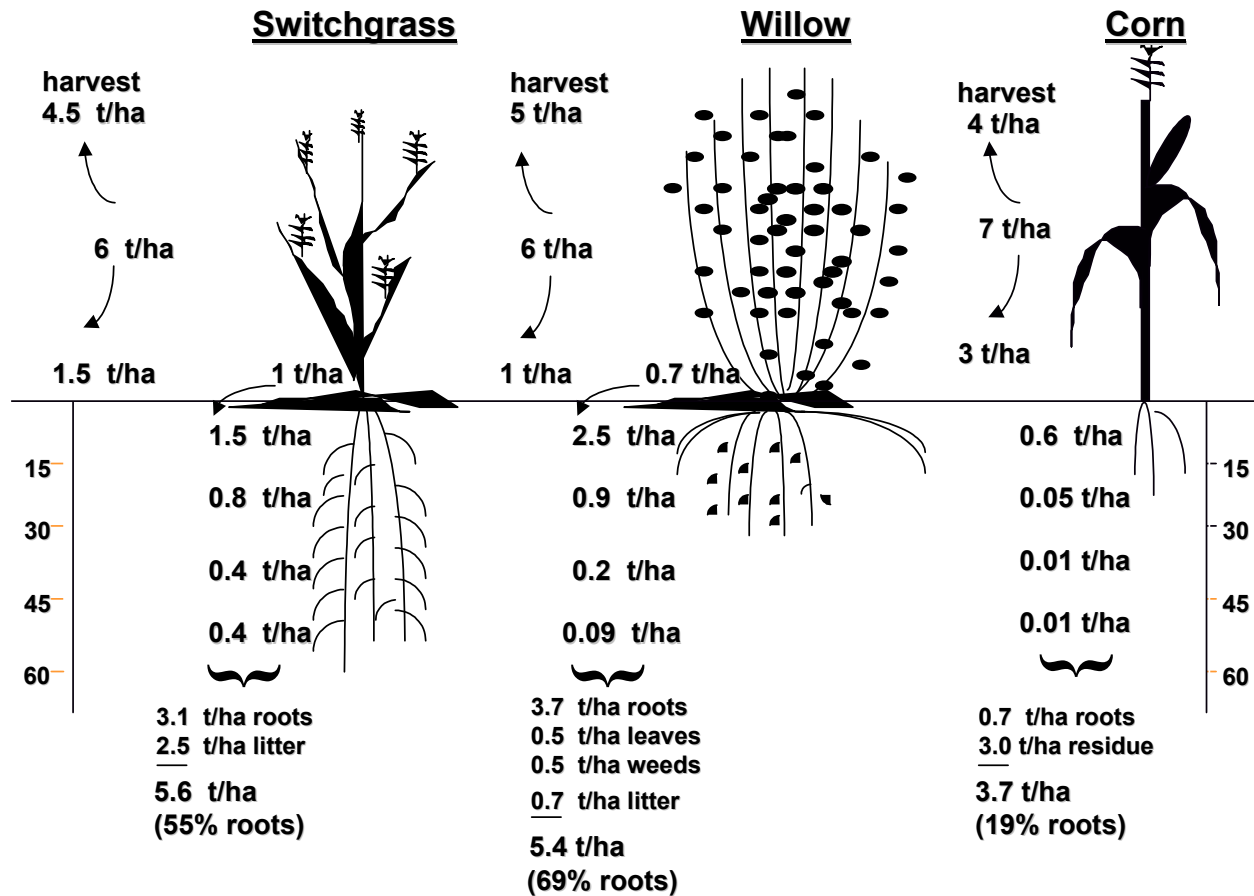

Source: Zan (1998)

Figure 3.15. Mean carbon partitioning in switchgrass, willow, and corn at the Seedfarm and Ecomuseum sites in 1996.

3.3.2. Soil Organic Carbon in 1996

In 1996 at the Ecomuseum, the soil organic carbon was significantly higher in the willow, followed by the switchgrass, and finally the corn. Rehfuess et al. (1990) showed that the conversion of agricultural land to short-rotation forests significantly increased earthworm (Lumbricidae) populations. Although no earthworm related data were collected, visual observations of higher earthworm populations at the Ecomuseum supported this theory. Increases in earthworm numbers can contribute to increased organic matter levels, as well as improved soil conditions (Rehfuess et al., 1990).

Perennial crops provide soil cover year long, preventing soil erosion and increasing water infiltration, thereby creating suitable conditions for potential organic matter accumulation. The

litter fall from the leaves adds valuable nutrients and organic matter to the soil, maintaining it in good health, and encouraging microbial activity.

Switchgrass roots made up 45% of the total biomass (relative to the aboveground), this represents a substantial carbon addition to the soil, especially considering that switchgrass fine root turn over is completed approximately once every four years (Dahlman and Kucera, 1965). Deep-rooted perennial grasses have been found to sequester significant amounts of organic carbon deep in the soil, well below the plough layer, as shown by research on South American grasslands (Fisher et al., 1994). The stored carbon would therefore be less prone to oxidation even when the crop is harvested, or plowed under, since it would be below the plough layer, thus contributing to carbon sequestration (Fisher et al., 1994). Switchgrass had greater fine root yields than willow (30-60 cm) at the Ecomuseum and at the Seedfarm. In spite of this, switchgrass failed to sequester more C than willows at these layers after 4 years, when managed for biomass production.

Native grass species were shown to have complete root turnover every 4 years (Dahlman and Kucera, 1965) compared to at least once per year for fine roots of deciduous tree species (Dewar and Cannell, 1992). Root turnover in short-rotation plantations is variable and poorly studied, but it is believed to be about 15 to 20% of root biomass (Ranney et al., 1991), although Rytter (1997) found willow fine root turn over to be as high as $4-5 \text{ yr}^{-1}$ in plantations in Sweden. In switchgrass, the plantations were only fully productive in 1996, therefore a complete root turnover may have not occurred, and the contribution of roots to soil organic may have not been complete. Alternatively, assuming the fine root turnover occurs every year for willows, fine roots would have contributed far greater amounts to soil organic matter. It is equally possible that since willows were left to grow undisturbed for 3 years (1993-1995) and then coppiced, part of their extensive root system died off, and may have contributed large amounts of carbon to the soil. Therefore, the amount of soil carbon that was measured in 1996 may be transient in nature and thus be a temporary carbon accumulation. In a study by Ford-Robertson (1997), roots of recently dead or harvested trees were shown to release substantial amounts of carbon. Some of this carbon may be incorporated into the soil fraction. The soil carbon pool is therefore dependent on the amount of carbon input and its turnover time (Ranney et al., 1991).

Overall, switchgrass at the Ecomuseum site was found to have 28% more total soil organic carbon from 0-60 cm, than the Seedfarm site. Significantly more litter carbon (62%) was

sampled at the Seedfarm site for switchgrass. Similarly, significantly greater root production at the Seedfarm site resulted in a 45% higher level of root carbon compared with the Ecomuseum site. Despite these differences in litter and belowground biomass, the switchgrass at the Seedfarm did not sequester greater soil carbon levels compared with the Ecomuseum.

Higher soil organic matter accumulation in productive soils (e.g. the Ecomuseum) has been explained by Sollins et al. (1984). Nutrient-rich sites have smaller C:N ratios in their soils as well as more microaggregates that protect carbon and nitrogen from being attacked by microorganisms, which leads to soil organic matter accumulation. A higher nutrient content at the Ecomuseum site, along with a potential increase in earthworm activity, may have caused the significant differences in the cropping systems.

Willow (147 t/ha) and switchgrass (123 t/ha) at the Ecomuseum site sequestered significantly more soil carbon than both the forest (109 t/ha) and abandoned field (109 t/ha) that were sampled for comparison analyses purposes. In fact, willow and switchgrass sequestered 34% and 16%, respectively, more soil carbon than either the forest or abandoned field. In contrast, at the Seedfarm site, there were no significant differences between the systems. Therefore, both switchgrass and willow, under adequate management after 4 years were able to surpass soil organic carbon levels in other perennial ecosystems. However, on less inherently fertile soils, such as the Seedfarm, perennial biomass crops may not necessarily increase soil organic matter contents.

3.3.2.1 1996 Accumulation Rates

In an attempt to quantify the amount of annual soil carbon stored from 1993 to 1996 under each cropping system, 1996 soil carbon levels from the corn systems were used as a benchmark to represent soil carbon levels at the time of switchgrass and SRF willow establishment, in 1993. Corn was planted on both sites in 1996. Prior to planting, the Ecomuseum was seeded to oil seed radish, and the Seedfarm was left fallow, both were plowed in the fall of 1993, in 1994 SRF willows were planted on the same plots and plowed under in the fall of 1995. Both of these crops may have added carbon to the soil. Nevertheless, assuming the corn soil carbon levels from 1993 to 1996 remained constant, the 1996 soil corn values were used to represent the 1993 benchmark soil values. Consequently, the 1996 switchgrass and willow systems were compared to the corn system, and carbon storage values were divided by 4 to represent annual incremental C storage in the systems, from 1993 to 1996.

At the Ecomuseum, corn stored 111 t/ha of soil organic carbon, switchgrass stored 123 t/ha, and willows stored 147 t/ha. Hence, soil organic carbon was calculated to increase by 3.8 t/ha/yr in the switchgrass plots, and by 9.0 t/ha/yr in the SRF willow plots. By the same token, over the same time period (from 1993 to 1996), SRF willows were found to sequester 5.3 tonnes of carbon/ha/yr more than switchgrass, when switchgrass soil carbon levels, as measured in 1996, were used as a benchmark.

The analysis of net carbon gain in the SRF willow and switchgrass assumes that the corn plots had a relatively constant organic carbon content during the course of the experiment. However, this may not have been the case due to the various cultivating practices since 1993. Therefore, the net soil carbon gains, as calculated for switchgrass and willow, when compared to the corn plots, may have been overestimated if the corn system was losing carbon.

3.3.3. Soil Organic Carbon in 1998

Once the 1996 soil organic carbon values were adjusted to the 1998 values by the regression equation:

1998 = -0.086 + 0.942*[1996 data] ($r^2=0.99$), willow, switchgrass, and corn had soil organic carbon concentrations (averaged over both sites) in 1996 of 122 t/ha, 106 t/ha, and 105 t/ha, respectively. Of which willow, as before, had significantly higher soil organic carbon than either switchgrass or corn (the transformation did not change the statistical results). In 1998, soil organic carbon results showed willow plots to maintain significantly higher levels than switchgrass and corn, however mean organic carbon levels decreased to 94 t/ha in the willows, 84 t/ha in the switchgrass and 83 t/ha in the corn plots. At the individual sites, no significant soil organic carbon difference between the cropping systems was found.

The most striking finding in 1998, was the large significant decrease in soil organic carbon in all plots, compared with 1996. Annual decreases from 1996 to 1998, in the 0-60 cm depth, at the Seedfarm were -7.9 t/ha/yr in the willow plots, -8.3 t/ha/yr in the switchgrass plots, and -11.7 t/ha/yr in the corn plots. At the Ecomuseum, losses ranged from -19.8 t/ha/yr in the willow, -14.3 t/ha/yr in the switchgrass, and -10.8 t/ha/yr in the corn plots. Most of the losses appeared in the 0-30 cm depth, with the 30-60 cm layer being more carbon stable.

Since no benchmark organic carbon values were obtained in 1993, it is not clear whether a decrease did not take place between 1993 and 1996 as well. However, despite not being able to compare 1996 and 1998 soil organic carbon values to actual 1993 benchmark levels, a real difference in the amount of soil organic carbon between the 1996 and 1998 sampling periods indicated that

in all cropping systems, a decrease in soil organic carbon was measured. The conversion from annually tilled systems (prior to the plantation of switchgrass and willow), to a no-till system, coupled with the additions of litterfall (dead biomass) of approximately 2.0 Mg/ha in switchgrass plots, and 1.8 Mg/ha in the willow (calculated as grand averages of 1996 and 1997 values from each plot), was expected to significantly increase the soil organic carbon.

Due to the continuous removal of switchgrass biomass each spring, there may have been a lack of organic input to maintain the stand, especially as it is reaching full establishment. Perhaps the 40-50 kg N/ha/yr applied at the Ecomuseum and at the Seedfarm was insufficient to provide nutrients to maintain the high yields, and at the same time sequester carbon. According to Campbell and Zentner (1993), even though annually cropped systems were fertilized based on soil tests, the crops were not receiving sufficient N to replace that being removed by the grain, pointing to the fact that soil and biomass nutrient pools are two distinct entities. Optimum fertilization levels for crop yields of switchgrass and SR willow may be below levels required for maintaining soil fertility, and may have to be increased over the long term to maintain soil C levels. Several studies indicate the importance of maintaining adequate fertilization levels, or improving, soil fertility to increase soil organic carbon in cropping systems (Campbell and Zentner, 1993; Mahli et al., 1997; Nyborg et al., 1998; Bruce et al., 1999; Lal et al., 1999).

The type of fertilizer applied will also influence the rate of carbon storage. A study by Mahli et al. (1997) showed urea fertilizer to be the least effective at increasing soil organic C under bromegrass, compared to ammonium nitrate, calcium nitrate and ammonium sulphate, which they speculated, may have been related to pH. The ammonium sulphate and ammonium nitrate treatments showed a marked decrease in soil pH (acidification), which reduces microbial activity and consequently organic matter decomposition. The decrease in pH did not take place in the urea treated soil. In addition, total C increased with increasing N fertilizer application (Mahli et al., 1997).

Carbon accumulation in perennials is mostly due to: the high allocation of carbon belowground, the greater transpiration leading to drier soils, the formation of stable aggregates within the extensive network of grass roots, and the absence of soil disturbance by tillage (Paustian et al., 1997). Unfortunately in 1998, no data on root distribution or mass was obtained. According to a study in the USA, land that was reverted to short grass prairie over the span of 50 years, accumulated on average 0.03 t/ha/yr of soil C in the top 10 cm (Burke et al., 1995). A similar study in Canada

found mean C accumulation to be 0.07-0.13 t/ha/yr in the top 15 cm, over 25 years (Dormaer and Smoliak, 1985). Another study which examined tall grass prairie planted on abandoned land found C accumulations in the range of 1 t/ha/yr in 0-10 cm, over 17 years (Jastrow, 1996), and a recent study by the Conservation Reserve Program found average soil organic carbon accumulations of 1.1 t/ha/yr, 5 years after converting cropland to perennial grasses (Gebhart et al., 1994). It would be interesting to know if any soil carbon losses took place during the first few years in any of the studies. An 11 year long study conducted in the semiarid prairie of southwestern Saskatchewan estimated organic C to increase in the top 15 cm of the soil by 1.6 t/ha over the 11 year period (Campbell et al., 1996). Most of this increase was observed to take place in the final 4 years, and was generally related to the amount of crop residue returned to the soil (Campbell et al., 1996).

As for the SRF willow losses, Hansen et al. (1993) collected data from different aged hybrid poplar plantations in north-central U.S., and found 12-18 year old plantations to store approximately 25 t/ha more soil carbon, from 0-100 cm, than adjacent row crops and grassland, but that 4-6 year old plantations lost soil carbon. Most of the losses were found to occur at 0-30 cm, and were attributed to mineralization. However, when soil organic carbon fluctuations were averaged over 30 years, an accumulation of 3.2 t/ha/yr was found, compared with adjacent row crops. Similarly, Grigal and Berguson (1998) studied hybrid poplars in Minnesota and found 7-8 year old plantations to have similar soil carbon from 0-100 cm, as agricultural land uses (corn, wheat, hay or grass). Based on estimates, they concluded that soil carbon was probably lost during the establishment phase, causing sharp decreases in soil carbon, and slow gains by the fifth year. By year 10-15, assuming a linear rate of soil carbon increase, the rate of soil carbon storage would eventually increase to between 1-1.7 t/ha/yr.

The current study is one of three in North America, which examines soil organic carbon sequestration amongst short rotation forestry. This study is unique to Canada, and it is the only one studying SRF willows. The other two studies are from the United States (Minnesota and North Central U.S.), and examine hybrid poplar soil from 0-100 cm (Grigal and Berguson, 1998; and Hanson, 1993, respectively). All of the three have reached similar findings; soil organic carbon decreases in the first few years (6-12 years) of SRF implementation.

If soil organic matter is to be maintained, sufficient N must be applied to the cropping system to compensate for the N removed in the aboveground biomass at harvest. For example,

substantial N was removed in 1-2 year old willow shoots, where N uptake was measured to be 120 kg/ha, yielding 9.2 Mg/ha and 13.3 Mg/ha in the 1 and 2 years old shoots, respectively (Nilsson, 1985). It is important to optimize productivity and nutrient utilization, while maintaining a healthy soil nutrient status.

3.3.3.1. 1998 Accumulation Rates

At the Ecomuseum, willows stored 98 t/ha of soil organic carbon, switchgrass stored 90 t/ha, and corn stored 83 t/ha. These levels were not statistically different from each other. Nevertheless, using 1998 corn plots as a benchmark, willows stored 14.3 t/ha more than the corn (translates into net organic carbon gain of 2.4 t/ha/yr, since 1993), switchgrass stored 7.1 t/ha (1.2 t/ha/yr,) more than corn, at the Ecomuseum.

At the Seedfarm, the willows stored 88 t/ha, switchgrass 77 t/ha, and corn 85 t/ha of soil organic carbon. By comparing willow and switchgrass to corn in 1998, willows gained 3.1 t/ha (0.5 t/ha/yr), and switchgrass lost 7.8 t/ha (1.3 t/ha/yr) of soil organic carbon, at the Seedfarm. Previous research has shown prairie grass soil carbon increases to be in the range of 0.01 to 1.0 t/ha/yr over the long term (17-50 years) (Dormaar and Smoliak, 1985; Burke et al., 1995; Jastrow, 1996) , therefore it is feasible that some losses will be incurred in some years.

3.3. General Conclusions

This study provided a first time assessment of the potential amounts of organic carbon sequestered in the biomass and soil under SRF willows and switchgrass, in eastern Canada. In 1996, after four years of production, results indicated that SRF willows had sequestered soil organic carbon (5.3 t/ha/yr) at one of the sites (Ecomuseum) compared with switchgrass. And that willows and switchgrass sequestered soil organic carbon, compared to corn (9.0 and 3.8 t/ha/year, respectively). On the second site (Seedfarm), no difference in soil carbon levels was measured between the SRF willows and switchgrass cropping systems.

A general decrease in soil organic carbon from 1996 to 1998 was measured (an average of 12 t/ha/yr was lost on both sites), which may be related to fertilization levels, but warrants further research. This is the first study in Canada to examine soil organic carbon levels under SRF willow and switchgrass plantations, comparing them to corn.

When comparing 1998 switchgrass and willow soil organic carbon values with corn, however, some carbon storage is noted from 0-60 cm depth. At the Ecomuseum site, switchgrass stored 7.1 t/ha more organic carbon than corn, and willows stored 14.3 t/ha more. At the Seedfarm, switchgrass lost 7.8 t/ha, compared to corn, and willow stored 3.1 t/ha more than corn. These differences however, were not statistically significant. Nevertheless, it appears that on a more nutrient enriched site, willow and switchgrass will sequester soil organic carbon, compared to corn. However, soil carbon levels may decrease at a given time, but for what length is unknown. In 1998, when comparing the perennial systems with the corn system, and averaging the values for both sites, switchgrass was calculated to decrease soil organic carbon levels, at 0-60 cm, by approximately 0.06 t/ha/yr, and willows increased organic carbon, at 0-60 cm, by 1.45 t/ha/yr. In years to come, these figures may change, as many studies point to perennial cropping systems sequestering less soil carbon (even losing soil carbon) during the first years of establishment, compared with subsequent years.

These results pertain only to the two study sites examined, on a Chicot soil type, from 1993 to 1998. The study highlights that soil organic carbon is dependent on a number of variables, as well as interactions, such as the annual amount of biomass returned to the soil, as well as the amount of nutrients applied to the soil. It appears that soil carbon accumulation is furthermore dependent on time related factors. The longer the rotations, the better chances of increasing the soil organic carbon pool.

Chapter 4

ECONOMIC, ENERGY, AND CARBON BUDGETING

Growing crops which are dedicated to energy production raises questions about the ultimate renewable nature of the fuel produced as well as the sustainability of the cropping system. This chapter reviews and updates the economics of growing switchgrass and SRF willows, and provides estimates of the amount of fossil fuel energy required, and the amounts of carbon emitted during the production processes of SRF willows and switchgrass. The budgets developed in this chapter were completed in March 1998. An updated version can be found in Girouard et al. (1999).

4.1 Methodology

The economic, energy and carbon budgets necessary to perform this study have been developed as one integrated model. Any change in cropping practice entered into the model resulted in an automatic readjustment of all three budgets. The model runs on Microsoft Excel spreadsheets.

4.1.1 SRF Willows

4.1.1.1 Economics

The costs associated with growing SRF willows in Quebec and Ontario were first estimated in 1995 (Girouard, 1995). Based on on-going field research and using the most recent methodological advances, the economics of growing SRF willows in commercial settings was revised. The economic model computes the full economic cost of growing SRF willows, which include all cash and non-cash costs incurred, along with relevant opportunity costs. Cost categories are variable costs (seeds, chemical fertilizers, fuel, lubricants, repairs and maintenance, operating interests), fixed cash and non-cash costs (interests payments, depreciation, insurance premiums), and opportunity costs (in this study, land rental and farmer's labor for performing field activities).

In order to ease the integration of energy and carbon budgets into the previous economic models (Girouard, 1995), dollar cost of production were computed by the following means. For any given production year, all costs were discounted to provide the present value of these costs. The present values in each production year were then summed to obtain the total present value

of costs incurred during the life span of the crop. Annual harvestable biomass yields were also discounted to present value, and summed to estimate the total present value of yield. Present value of costs per oven-dried Megagram (odMg) were computed by dividing total discounted costs by total discounted yield. Using the same input data, the former (Girouard, 1995) and present models were compared for consistency, the results were found to be within \pm \$3/odMg of each other. The newer model therefore, does not materially affect production cost estimates.

Farmers were assumed to grow SRF willows for a period of 20 years, which results in five harvests over the life span of the plantation, using a four-year harvest cycle. The willows were assumed to be planted using a conventional vegetable transplanter and 30-cm long cuttings; this option proved to be relatively cost effective in a previous study (Samson et al., 1995). Further reductions in planting costs using planters developed specifically for SRF willows would improve the cash flow of SRF plantations but not substantially affect the average cost per tonne of biomass produced over a 20-year life span. Cuttings were assumed to be grown by the farmer or by one in his vicinity. Input data developed by Samson et al. (1995) were used to provide an estimated cost per cutting produced.

Short rotation forestry willow establishment was assumed to begin by spraying the site in the fall prior to planting, with a broad-spectrum herbicide (Roundup[®]), followed by plowing. In the spring, the site was harrowed twice and planted. A combination of pre-emergent (Simazine[®]) and post-emergence herbicides (Assure[®]) were sprayed during the growing season to provide weed control, in addition to rotary hoeing and inter-row cultivation. No weed control strategies were assumed to be required for the second growing season, as willow canopy closure should prevent significant weed growth. Chemical weed control was assumed to be necessary only in the year following a harvest.

Fertilizer recommendations for SRF plantations have not been well defined to date. Therefore the assumptions made in Samson et al. (1995) were assumed to be relevant to this study. The logistics of applying fertilizers in years 3 and 4 of a harvest cycle, where tree height is a barrier to using regular equipment, still demands practical solutions for large plantations. Adding more fertilizers in the first two years may be a solution, however research on guidelines is required so as to avoid non-point source pollution.

Harvesting of the willow was assumed to be performed every four years using a self-propelled direct chipping machine; namely a Class-Jaguar harvester. It was assumed that the chipped material was forwarded to a farm dumper wagon attached to the harvester. Once full, the wagon was replaced by an empty wagon, while it was pulled to a depot on the farm and emptied. Semi-trailer trucks collect the material and deliver it to a conversion plant located within a 60 km radius, following a pre-determined schedule designed to provide a steady throughput of material to the plant. This scenario avoided the issue of chip spoilage in year-round storage, an issue which still remains to be successfully dealt with, if SRF willows are going to be supplying conversion plants on a 12-month basis.

There still exists a lot of uncertainty regarding the cost of harvesting SRF willows. Most studies performed in Europe with direct chipping machines such as the Class-Jaguar were performed on one or two-year old trees, which makes it difficult to estimate what harvester productivity would be with 4-year old trees. A machine productivity of 0.25 ha/hr was chosen for this study, based on the literature, and is independent of mean annual yield increments achieved.

Three farm dumper wagons were assumed to be sufficient to transport the chipped material and prevent the harvester from stopping unduly. The cost of this operation was derived from studies published for transporting hay on farms (CREAQ, 1994). The implicit assumption was that the bulk density of wood chips and large square bales of hay were relatively similar, and that forage silage wagons would be an unnecessary expense to handle the material. The above scenario should provide a rough estimate, in the worst case.

Trucking costs had been estimated in the previous study (Samson et al., 1995) at \$8.00/odMg for a 40-km haul, this being based on previous literature and quotes for grain handling. Since this study also includes an energy and carbon emission component, it was decided to breakdown the costs incurred of operating a truck in Canada. The estimates were developed using a study on the costs of operating motor carriers in Canada (Transport Canada, 1996). Costs were developed assuming the truck is part of a fleet, which is probably a fair assumption given the supply is for a large conversion plant using SRF chips.

The annual harvestable yield of SRF willows on the two Ste-Anne-de-Bellevue sites averaged 8.2 t/ha over 4 years (1994-1997) and ranged from 6.9 to 10.2 odMg/ha/yr. This range is similar to that of 7-11 odMg/ha/yr first estimated in a report by Samson et al. (1995), and was therefore

considered to be relevant for this study. To reflect the fact that productivity is lower during the establishment years of the crop, the assumption was made that annual growth in the first year would be 15% of the mean annual increment obtained over a 4-year cycle in an established plantation, 65% in the second year, and 100% in years 3 and 4. This results in the mean annual increment over the first cycle to be 70% of what will be achieved in the following cycles.

4.1.1.2 Energy Budgeting

One of the main issues related to growing crops for the purpose of producing energy relates to how much fossil fuel energy is required during the production process. In this study, the fossil fuel energy expended from the fields to the conversion plants was estimated.

As discussed previously, the energy budget is integrated into the economic and carbon emission models. The sources of fossil fuel accounted for were; the energy used in manufacturing farm inputs, diesel fuel energy used for cropping activities and energy in oil and lubricants. Energy consumed during the manufacturing of farm equipment was not considered, neither was any provision made for the energy opportunity cost for using the land for growing bio-energy crops (equivalent to land rent in an economic model), neither for the energy consumed by farm labourers.

The energy expended by producing SRF cuttings on an on-farm cutting nursery was estimated by modifying the SRF energy model to fit the cropping practices described in Samson et al. (1995). The cuttings were assumed to be produced on an on-farm nursery or by a farmer in the vicinity.

The amount of herbicide and fertilizer used each year were accessed from the economic model. Values from the literature were used to determine the energy associated with the use of one elemental unit of nitrogen, phosphorus, and potassium fertilizers, and one unit of active herbicide ingredient.

Diesel fuel energy required for the performance of each farm operation was computed by estimating the number of liters of diesel fuel required, sourcing the information from the literature (CREAQ, 1987) for pre-harvest operations. These values, independent of mean annual yield increments achieved, were then multiplied by the energy content of a litre of diesel fuel, 0.03868 GJ. For harvest operations, fuel consumption was estimated using an engineering

formula relating engine horsepower rating to fuel consumption.. For off-farm transport, fuel consumption per kilometer traveled was estimated from a study on trucking cost (Transport Canada, 1996). Energy contained in oil and lubricants was assumed to be 15% of the diesel fuel energy required for each operation.

Finally, using the higher heating value (HHV) of willow biomass, 19.5 GJ/odMg, the energy output:input ratio of the biomass produced was estimated.

4.1.1.3 Carbon Emissions

Rising concerns about climate change and the need for countries to take action to reduce their GHG emissions to comply with international treaties, prompted a re-assessment of biofuels. This section of the report provides an assessment of the quantity of carbon released as carbon dioxide (CO₂) during the production of SRF willows.

As discussed previously, the carbon emission budget was integrated into the economic and energy models. Carbon released during the manufacturing of farm inputs (such as fertilizers), burning diesel fuel during cropping activities, and from the use of oil and lubricants, was accounted for in the budget. Carbon emitted during the manufacturing of farm equipment was not included.

To determine carbon emissions associated with the use of one elemental unit of nitrogen, phosphorus, and potassium fertilizer, the quantity of each type of fossil fuel energy required for the manufacture of each fertilizer product was retrieved from the energy model, and multiplied by the carbon released from combusting one Gigajoule of each fuel. The same procedure was followed to estimate the carbon emitted from the use of herbicides.

Three main sources of energy were used during the manufacture of farm inputs: electricity, natural gas, and diesel fuel. Natural gas was estimated to emit 13.53 kg C/GJ (National Energy Board, 1991), diesel fuel 19.28 kg C/GJ (National Energy Board, 1991), and electricity 65.68 kg C/GJ. The electricity emissions were estimated by using the following assumption: 1) farm inputs were manufactured in the United States where almost 75% of the electricity is generated by using fossil fuels (Marland and Turhollow, 1991); 2) electricity originated from 75% coal

combustion, and 25% from hydro/nuclear (assumed to be carbon neutral); 3) coal released 26.27 kg C/GJ and was converted into electricity with a 30% efficiency¹.

Carbon emissions related to the use of diesel fuel for cropping activities were computed by multiplying the number of Gigajoules of fuel required per hectare for a particular operation by 19.28 kg C/GJ. Emissions related to oil and lubricants were assumed to be 15% of those estimated for diesel fuel for each farm activity.

Carbon emissions incurred during the production of cuttings used for the establishment of SRF willows plantations were estimated by adjusting the SRF carbon emission model developed for this study to the conditions described in Samson et al. (1995), for an on-farm cutting nursery.

The fossil fuel carbon emissions estimated were then analyzed in terms of their intensity vis à vis to the quantity of biomass energy produced. The analysis involved three levels, at each of which the total kilograms of fossil fuel carbon emitted were divided by total number of Gigajoules of harvestable biomass energy produced, a ratio called carbon requirement, and expressed mathematically as:

$$\text{Carbon requirement} = \frac{\text{Total carbon emitted}}{\text{Total harvestable biomass energy}} = \frac{\text{kg C/odMg}}{\text{GJ/odMg}} = \frac{\text{kg C}}{\text{GJ}}$$

The first level of analysis estimated the carbon requirement for the crop without any provision for soil or biomass carbon changes resulting from introducing the crop to an area of land, which is the most common estimate used in the literature.

The second level of analysis introduced the concept of soil organic carbon accumulation in the computation of the carbon requirement. As discussed in Chapter 3, soil organic carbon accumulation is governed by many factors, but it is generally agreed that perennial crops result in soil carbon sequestering on most conventionally cropped land. Therefore, introducing SRF willows may create a potential sink of carbon, which may partly, or completely, offset the emissions of fossil fuel carbon produced during its production cycle. Four levels of soil organic carbon accumulation (250, 500, 750 and 1,000 kg C/ha/yr) were investigated. Results of the 1996 soil organic carbon sampling at the Ecomuseum site were presented in Chapter 3 and

¹ Carbon emissions from coal combustion were estimated as the average for imported bituminous, Canadian bituminous, sub-bituminous, lignite and anthracite (National Energy Board, 1991).

suggested much higher accumulation rates, using soil organic carbon levels measured in adjacent corn plots as benchmarks. However, 1998 soil carbon data (Chapter 3) showed carbon sequestration levels to be lower than in 1996. In the absence of well established accumulation rates, 500 kg C/ha/yr was chosen as a base case scenario for the simulations performed in this chapter. Net carbon emissions for each crop were computed and used to evaluate the carbon requirement values.

Growing SRF willows (and switchgrass) may also result in an increased amount of carbon being tied-up in the biomass (stem, leaves, roots, litter), compared to conventional crops; such as corn and soybeans. The issue is fairly complex to analyze, as the crop(s) being replaced by the SRF willows (or switchgrass) will greatly influence any potential carbon gains or losses. In this study, the assumption was made that SRF willows would follow a continuous grain corn crop².

To act as an aboveground carbon sink, carbon accumulated over a 4-year harvest cycle in SRF willow biomass has to be greater than that from the prior vegetation on the landscape. In such a case, willow will act as a carbon sink only during the first harvest cycle, as the second cycle will substitute for a previous willow crop, with a similar aboveground C accumulation. Aboveground C sequestration would therefore only occur during the first harvest cycle, over the 20 year lifespan of the plantation. This is the assumption followed, when performing simulations in this chapter. Nonetheless, given that a certain fixed amount of hectares are required to supply a conversion facility, some land will return to conventional cropping while others will be planted to energy crops to ensure a sufficient supply of raw material. The gain/loss in biomass carbon should therefore last throughout the duration of the life of the conversion facility.

4.1.2 Switchgrass

4.1.2.1 Economics

Farmers were assumed to grow switchgrass for a 10-year period. In the fall prior to planting, the fields were assumed to be sprayed with a broad spectrum herbicide (Roundup[®]) and plowed. In the spring, the fields were harrowed twice and planted using a regular cereal grain drill equipped with a forage seed box.

² This assumption was convenient as corn above- and below ground biomass productivity, as well as biomass carbon levels, were measured in corn plots established adjacent to the switchgrass and SRF willow plots in Ste-Anne-de-Bellevue (see Chapter 3 for more details). Productivity of the three crops on the same soil was also determined.

Broadleaf weed control in the establishment year was assumed to be achieved by spraying Laddock[®] herbicide. No weed control was assumed to be necessary for the following 9 years.

When the crop is harvested in the spring, fertilizer requirements were assumed to be between 50 and 75 kg N/ha, with 60 kg N/ha and 10 kg P/ha as a base case. No fertilization is required in the establishment year. Phosphorus and potassium fertilization should be evaluated through a series of soil tests, i.e. they are site specific. In the event the crop is harvested in the fall, the fertilizer requirements were estimated to be 70 kg N/ha, 15 kg P/ha and 30 kg K/ha. From a study on nutrient extraction rates performed on switchgrass, it was measured that NPK fertilization requirements should be 60 kg N/ha, 16 kg P/ha, 124 kg K/ha for fall harvested switchgrass (assuming a yield of 13 odMg/ha) (Table 4.1). However, the K requirements for a fall harvest were unrealistically high to be used as annual applications, as switchgrass has a large root system and shows little response to potassium in fertilization studies . Therefore, K levels were reduced to more sparing levels.

Table 4.1: Nitrogen, Phosphorous, and Potassium Content in Switchgrass Plants Collected from a Fall and Spring Harvest		
Nutrient	Fall 1995 Fraction, %	Spring 1996 Fraction, %
Nitrogen	0.46	0.33
Phosphorous	0.12	0.04
Potassium	0.95	0.06

Adapted from Goel et al., 1998.

Switchgrass harvesting was assumed to be performed with a self-propelled haybine and a large square baler. The choice of the square bales over round bales were due to the fact that large round bales, with high densities, lead to oversized truckloads in eastern Canada. The majority of round bales currently produced in this region for sale off farms, are small round bales (1.2 m x 1.2 m). When large volumes of hay/straw need to be transported (for instance, for the mushroom industry), large square bales are increasingly being used. The costs of square baling was estimated using engineering formulas and from discussions with large square baler operators in Quebec and Ontario.

Switchgrass large square bales were assumed to be stored on farms for future delivery to a conversion plant located within a 60 km radius. No provision was made in the budget for storage costs, as they were not included in the SRF budget either. Regardless, this cost item should not materially affect the average cost of production, as the requirement for switchgrass storage is only a well-drained site and use of a good quality tarp. On-farm and off-farm transportation costs were estimated using the same methodology as for SRF willows, except that flat bed carriers were used to transport the bales.

Switchgrass fall productivity of the Cave in Rock variety on sites in Ste-Anne-de-Bellevue ranged between 8-13 odMg/ha since 1994 (Chapter 2). In the event that the switchgrass is harvested in the spring, approximately 24% of the material may become unharvestable (Goel et al., 1998), which results in harvestable yields of 6-10 odMg/ha. Both the fall and spring harvest regimes were investigated in this study, although only the spring harvest regime has been thoroughly field tested in eastern Canada to date. Fall harvested and spring harvested sites at the same farm would decrease storage space by half and increase the operating time of the

harvesting equipment, which would reduce costs. However, the effect of fall harvesting on winter survival of the stands remains to be investigated.

Finally, switchgrass is a fairly slow crop to establish and, as with SRF willows, this was taken into consideration in the budgeting procedure. From the experience gained in the research sites in Ste-Anne-de-Bellevue, a switchgrass field usually becomes fully established in its third growing season. The model assumed the productivity of switchgrass during the establishment year to be 35% of the full yield potential (i.e. yield after the third growing season), 80% in the second growing season and finally attaining full productivity in the third growing season.

4.1.2.2 Energy Budgeting

The switchgrass energy model used the same assumptions as the SRF energy model, with two exceptions: the amount of energy attributed to seed production was assumed to be 10% of the energy required during the first growing season of a switchgrass crop. The higher heating value (HHV) of switchgrass was estimated to be at 17.5 GJ/ha.

4.1.2.3 Carbon Emissions

Carbon emissions were computed following the methodology developed for SRF willows.

4.2 Results

4.2.1 SRF Willows

4.2.1.1 Economics

SRF willows can be produced and delivered to a conversion plant for \$58-\$85/odMg in the study region (Table 4.2), which is similar to previous estimates (Samson et al., 1995). For the base case scenario (Table A3.1, Appendix 3), delivered cost to a conversion plant was estimated to be \$68/odMg. Using an average of the yields obtained during the first four years of the plantations in Ste-Anne de Bellevue; 8.2 odMg/ha/yr (see Chapter 2), the delivered cost would be approximately \$76/odMg. Sensitivity analyses performed on the base case value indicated that varying land rent values from \$75 to \$175/ha would result in a \pm 9% change in delivered cost (see Appendix 4 for details).

Table 4.2: SRF Present Value of Costs of Production in Function of Mean Annual Yield Increment					
	Mean Annual Yield Increment (odMg/ha)				
	7	8	9	10	11
\$/odMg	85	76	68	63	58

Over the 20-year period the farmer has the SRF willow plantation, nearly 46% of the expenses incurred are for harvesting and transporting the chips (Figure 4.1). Establishment costs represent a substantial cash outflow at the beginning of the plantation but are a relatively minor expense when examined over a 20-year period.

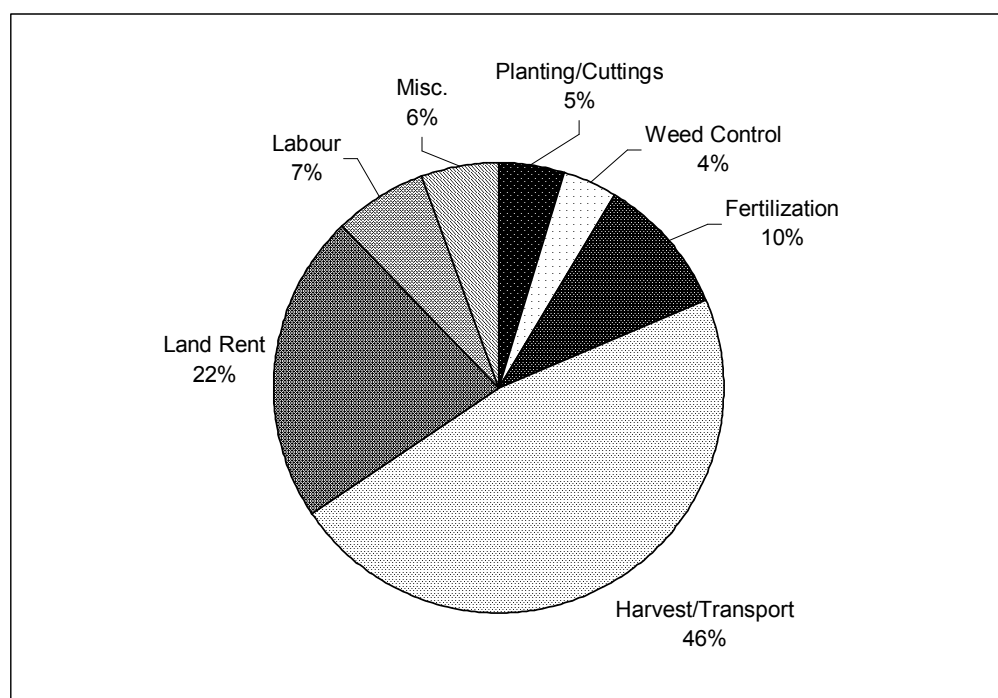

Figure 4.1. Economic Cost Breakdown for SRF Willow

4.2.1.2 Energy Budget

For the base case scenario, growing SRF willows was estimated to require on average 5.50 GJ/ha annually from fossil fuels (Table A3.4, Appendix 3). Most of the required energy is related to fertilization (57%) and harvest/transport of the chips (38%) (Table A3.2, Appendix 3). The energy ratio was estimated to be nearly 30, i.e. the biomass energy produced by the SRF crop is 30 times higher than the amount of fossil fuel energy input required for its production. The ratio varied between 24 and 34 for yields between 7 and 11 odMg/ha/yr (Table 4.3).

Table 4.3: Energy Ratio for SRF Willows for Different Mean Annual Yield Increments					
	Mean Annual Yield Increment (odMg/ha)				
	7	8	9	10	11
GJ Biomass	24.41	27.13	29.70	32.13	34.44
Energy/GJ					
Fossil Fuel					
Used					

4.2.1.3 Carbon Analysis

For the base case scenario, SRF willows were estimated to release 104 kg C/ha annually in the form of fossil fuel utilization (Table A3.4, Appendix 3), 55% of which was related to the use of fertilizers and 39% to the harvest/transport (Table A3.3, Appendix 3). These items represent 94% of the fossil fuel carbon emitted in the production of SRF willow.

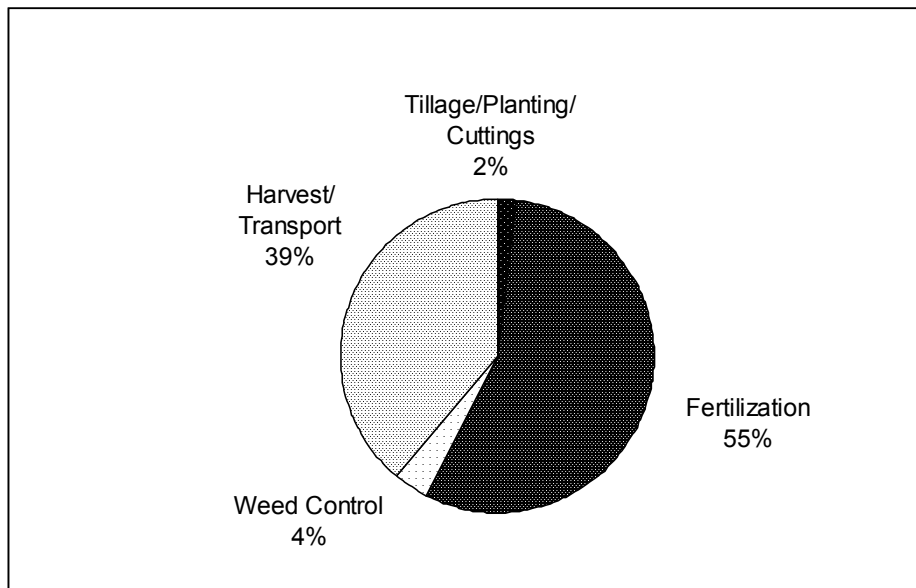

Figure 4.2. Carbon Budget Breakdown for SRF Willow

Without accounting for any potential carbon sequestration in the soil or the biomass, SRF willows were estimated to release between 0.54 kg and 0.77kg C/GJ of harvestable biomass energy (Table 4.4).

Table 4.4: Carbon Requirement Based on Fossil Fuel Used for SRF Willows for Different Mean Annual Yield Increments					
Mean Annual Yield Increment (odMg/ha)					
	7	8	9	10	11
C1: Carbon Requirement (kg C/GJ)	0.77	0.69	0.63	0.58	0.54

A key component of this study was to evaluate the possibility of sequestering carbon in soils while growing perennial energy crops, such as SRF willows and switchgrass. The scenario involving no carbon sequestering is presented in Table 4.4. Using the base case yield of 9 odMg/ha/yr, the impact of four soil organic carbon accumulation rates (250, 500, 750 and 1,000 kg/ha/yr) was evaluated (Appendix 4). The resulting values for carbon requirement (C2 in Figure 4.3) varied between -0.88 and -5.43. The negative values indicate that the soil organic carbon accumulation rates more than offset the emissions of carbon resulting from the production of the crop. For each Gigajoule of biomass energy produced, 0.88 kg to 5.43 kg of carbon were sequestered in the soil. It was estimated that a rate of soil organic carbon accumulation of 104 kg/ha/yr would be necessary to offset the fossil fuel emissions, i.e. for the crops to be carbon neutral.

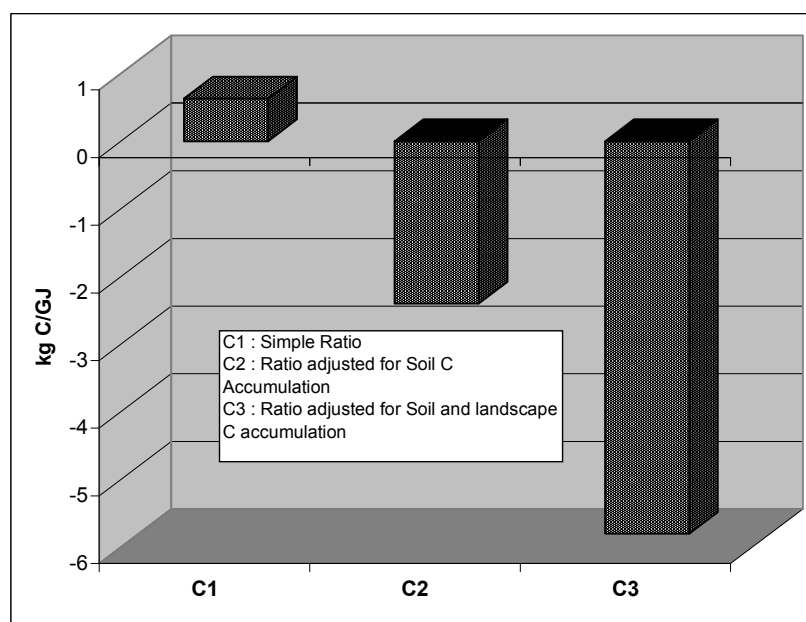

Figure 4.3. Carbon Requirements for SRF Willow (assuming a soil C sequestration of 500 kg C/ha per year). For more details refer to Appendix 4

The last estimate computed includes the adjustment for carbon tied up in the landscape as biomass, compared to the former land use. Carbon sequestered in the biomass of corn was used to estimate any gains or losses, which modified the values to a range of -4.29 to -8.83 kg C/GJ (Table A4.5, Appendix 4). The values of the three carbon requirement estimates computed using the base case values are shown in Figure 4.3.

4.2.2 Switchgrass

4.2.2.1 Economics

Switchgrass grown under a spring harvest regime can be produced and delivered to a conversion plant for \$46-\$68/odMg in the study region (Table 4.5). For the base case scenario (Table A3.1, Appendix 3), delivered cost to a conversion plant was estimated to be \$55/odMg. Sensitivity analysis performed on the base case value indicated that varying land rent values from \$75 to \$175/ha would result in a \pm 13% change in delivered cost (Appendix 5).

Switchgrass harvested in the fall was estimated to cost an average of 17% less to produce than in the spring (Table 4.5). The increase in harvestable biomass, in response to the elimination of overwintering losses more than offset the additional fertilizer requirements.

Table 4.5: Switchgrass Present Value of Costs of Production in Function of Maximum Annual Productivity

	Average Spring Yield (odMg/ha)				
	6	7	8	9	10
\$/odMg	68	61	55	50	46
	Average Fall Yield (odMg/ha)				
	10.5	12	13		
	47	43	41		

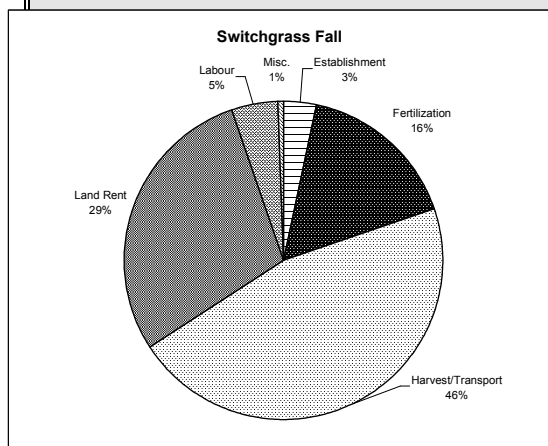

, on average, over the 10-year period that farmers keep expenses incurred are for harvesting and transporting the production, and 10% for all other costs (Figure 4.4).

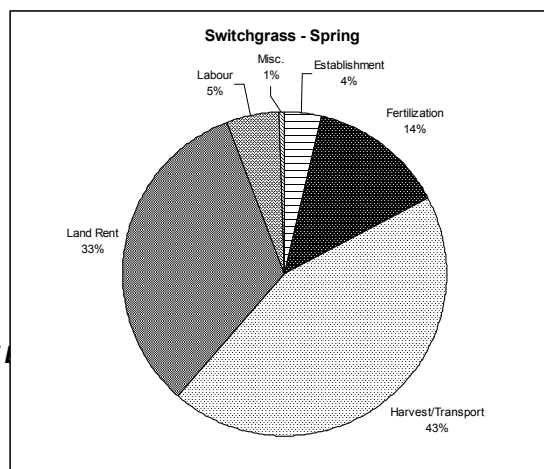
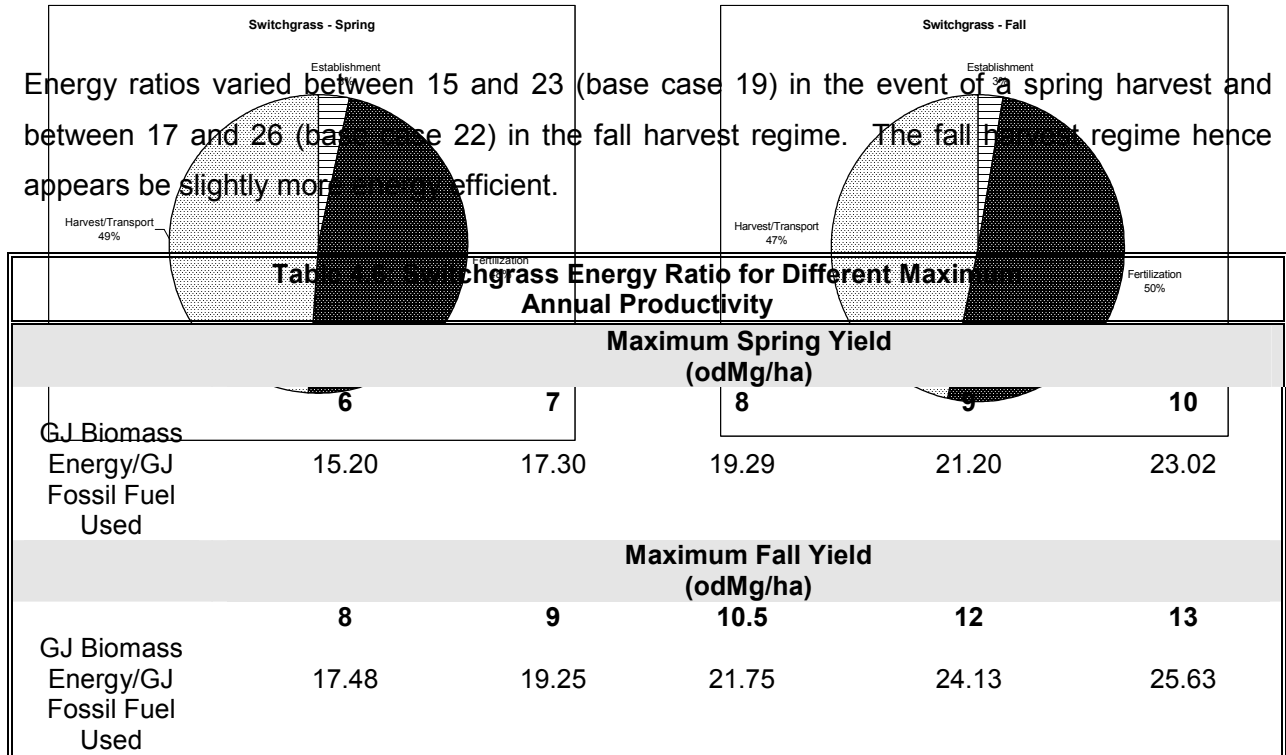

Figure 4.4. Economic Cost Breakdown for Spring and Fall Switchgrass

4.2.2.2 Energy Budget

For the base case scenarios, switchgrass was estimated to require on average 6.6 and 7.7 GJ/ha/yr for spring and fall harvest, respectively (Tables A3.5 and A3.6, Appendix 3). In both cases, most of the energy required was related to fertilization (51.5%) and harvest/transport of the crop (45.5%) (Table A3.2, Appendix 3).

Energy ratios varied between 15 and 23 (base case 19) in the event of a spring harvest and between 17 and 26 (base case 22) in the fall harvest regime. The fall harvest regime hence appears to be slightly more energy efficient.



4.2.2.3 Carbon Analysis

On a per hectare basis, switchgrass was estimated to release 118.10 kg C/ha/yr (spring) and 141.65 kg C/ha/yr (fall) from the use of fossil fuels (Tables A3.5 and A3.6, Appendix 3). On average, for both systems, 49% of the emissions were related to the use of fertilizers and 48% to the harvest/transport. These two items represent 97% of fossil fuel carbon emitted (Figure 4.5).

Figure 4.5. Carbon Budget Breakdown for Spring and Fall Harvested Switchgrass

Without accounting for any potential carbon sequestered in either the soil or the biomass, switchgrass harvested in the spring was estimated to release between 0.80 kg and 1.20 kg C/GJ of harvestable biomass energy produced (Table 4.7). In the fall, the ratio varied between 0.73 and 1.06 kg C/GJ.

Table 4.7: Switchgrass Carbon Requirement Based on Fossil Fuel Use for Different Maximum Annual Productivity					
Average Spring Yield (odMg/ha)					
	6	7	8	9	10
C1: Carbon Requirement (kg C/GJ)	1.20	1.06	0.95	0.86	0.80
Average Fall Yield (odMg/ha)					
	8	9	10.5	12	13
C1: Carbon Requirement (kg C/GJ)	1.06	0.97	0.86	0.77	0.73

Using the base case yield of 8 odMg/ha/yr for the spring harvest regime, the impact of four soil organic carbon accumulation rates (250, 500, 750 and 1,000 kg/ha/yr) were evaluated. The resulting values for carbon requirement (C2 in Figure 4.6) were -1.00 to -6.86 kg C/GJ (Appendix 5). In other words, for each Gigajoule of biomass energy produced, between 1.00 kg and 6.86 kg of carbon were sequestered in the soil. It was estimated that a rate of soil organic carbon accumulation of 121 kg/ha/yr would be necessary to simply offset the fossil fuel emissions resulting from crop production, i.e. for the crop to be carbon neutral.

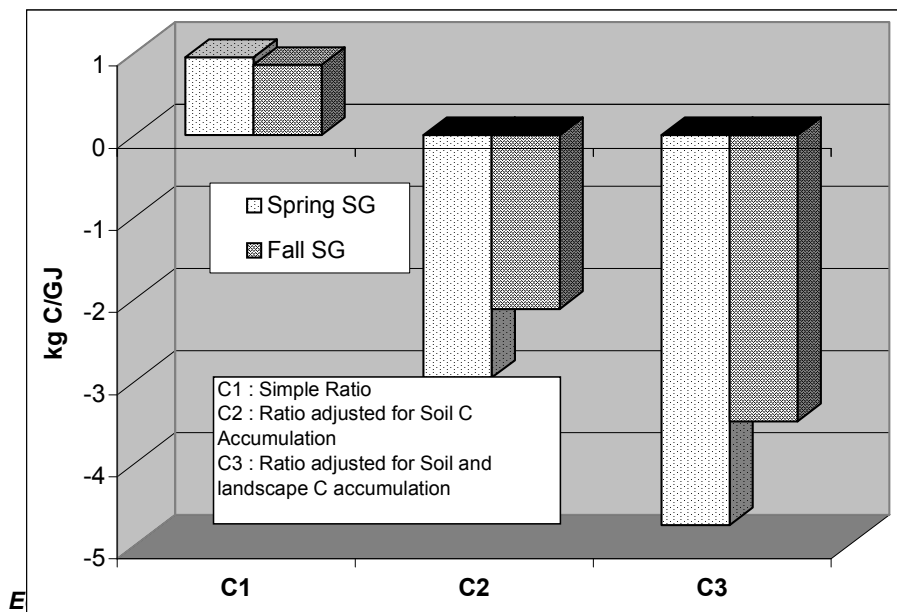

Figure 4.6. Carbon Requirements for Spring and Fall Harvested Switchgrass (assuming a soil C sequestration of 500 kg C/ha per year)[‡]

[‡] For more detail refer to Appendix 5 and 6

The same analysis performed on the fall harvest regime resulted in carbon requirement values ranging between -0.63 and -5.09 kg C/GJ, with a breakeven value of 141 kg C/ha per year (Appendix 6). The greater amount of biomass harvested in the fall over the spring, for the same soil carbon accumulation rates explains the lower carbon requirement values obtained in fall.

The final estimates computed include the additional carbon tied up in the landscape as biomass, compared to the former land use. Carbon sequestered in the biomass of a corn crop was used to estimate gains/losses, which resulted in the carbon requirement estimates (C3) to further decrease to -2.80 to -8.65 kg C/GJ (in spring, Table A5.5, Appendix 5) and -2.00 to -6.46 kg C/GJ (in fall, Appendix A6.5, Appendix 6). The value of the carbon requirement estimates, computed using the base case values, are shown in Figure 4.6.

4.3 Discussion

Assuming no soil organic carbon accumulation for both SRF willows and switchgrass took place, carbon emissions were estimated to be between 0.63 and 0.95 kg C per Gigajoule of bioenergy delivered to a conversion facility (C1 in Figure 4.7). Liquid fossil fuels such as gasoline and diesel emit approximately 19 kg C/GJ. Without accounting for any carbon sequestering, bioenergy produced from these two crops would thus release approximately one-twentieth the emissions of liquid fossil fuels, on an energy basis. Conversion of these feedstock into liquid fuel, such as ethanol would require a carbon fossil fuel input, but overall the net carbon balance will mark an improvement over gasoline, as the lignin available in the feedstock would be burned to supply the process energy required during conversion.

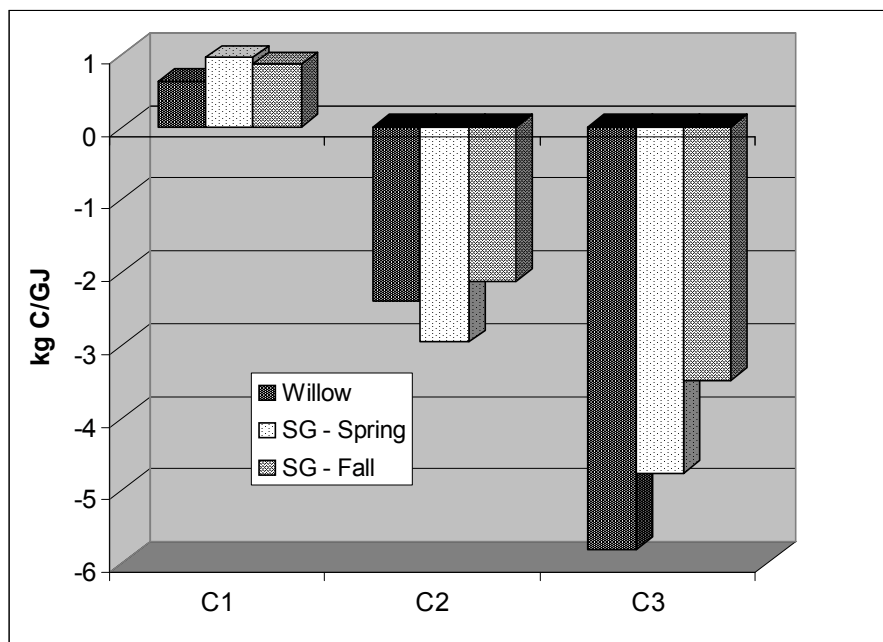

Figure 4.7. Comparison of Carbon Requirements for Cropping Systems (assuming a soil C sequestration of 500 kg C/ha per year)

One of the objectives of this study was to investigate the potential impact of carbon sequestering on net carbon emissions generated during the cultivation of switchgrass and SRF willows for the production of bioenergy. It was estimated that annual soil carbon accumulation rates of approximately 104 kg C/ha for SRF willows and between 121-141 kg C/ha for switchgrass would completely offset the fossil fuel CO₂ generated during the production of either crop. At any higher level of soil carbon accumulations, the crops become carbon sinks (C2 in Figure 4.7). The base case rate was assumed to be 500 kg C/ha per year for the simulations, but additional research is necessary to quantify more accurately the long term carbon accumulation rates for switchgrass and SRF willows in eastern Canada.

The conversion of forest to agricultural land during pioneer settlement resulted in a large input of carbon into the atmosphere: agricultural crops accumulating much less biomass per unit of land than forest. Rotating crops on agricultural land also changes the total amount of carbon sequestered in the biomass (or landscape) due to variations in above and belowground biomass productivities. It was decided for this study to evaluate these changes in the event the bioenergy feedstocks investigated replaced a corn crop. Including an annual soil organic carbon accumulation rate of 500 kg C/ha (the base case in this study) for both SRF willows and switchgrass, annual carbon sequestering was estimated to be 5.80 kg C/GJ for willows and 3.48

to 4.75 kg C/GJ for switchgrass (C3 in Figure 4.7). Based on these results, it is likely that a combination of carbon sequestration in either soil or biomass should make these two feedstocks at least carbon neutral.

Carbon sequestration and/or loss in soils and in biomass is a phenomenon which is influenced by the present and past cropping system. New soil equilibrium are reached for each new crop grown, and biomass carbon levels return to pre-existing conditions when the land is returned to the former crop. If biofuel production facilities are built, a constant input of raw material grown from a fixed amount of land will be required. Within this fixed land area requirement, the situation of the individual fields will be dynamic as some farmers return their land to food crops, while others introduce bioenergy crops on their land. Carbon sequestering resulting from rotations including switchgrass and SRF willows should be investigated in the future.

Using the base case scenarios, it was also estimated that both bioenergy crops had positive output to input energy balances, approximately 19-22 for switchgrass and 30 for SRF willows (Figure 4.8). As a comparison, the energy balance range for grain corn is from 3 to 6 in the study region (Hill and Nault, 1995). These high energy ratios are equivalent to annual energy gains per hectare of 121- 160 GJ for switchgrass, spring and fall harvest regimes respectively, and 159 GJ for SRF willows.

In terms of economics, SRF willows proved to be more expensive to grow than switchgrass in eastern Canada, which was also the conclusion reached in 1995 (Samson et al., 1995). In terms of carbon offset and energy output:input ratio, SRF willows appeared nonetheless superior (Figures 4.7 and 4.8). A trade-off between economics and energy/carbon offset exists and therefore needs to be considered. From a practical standpoint, the main limitation to the wide adoption of SRF willow production remains that production is restricted to unused and/or non-tile drained farmland.

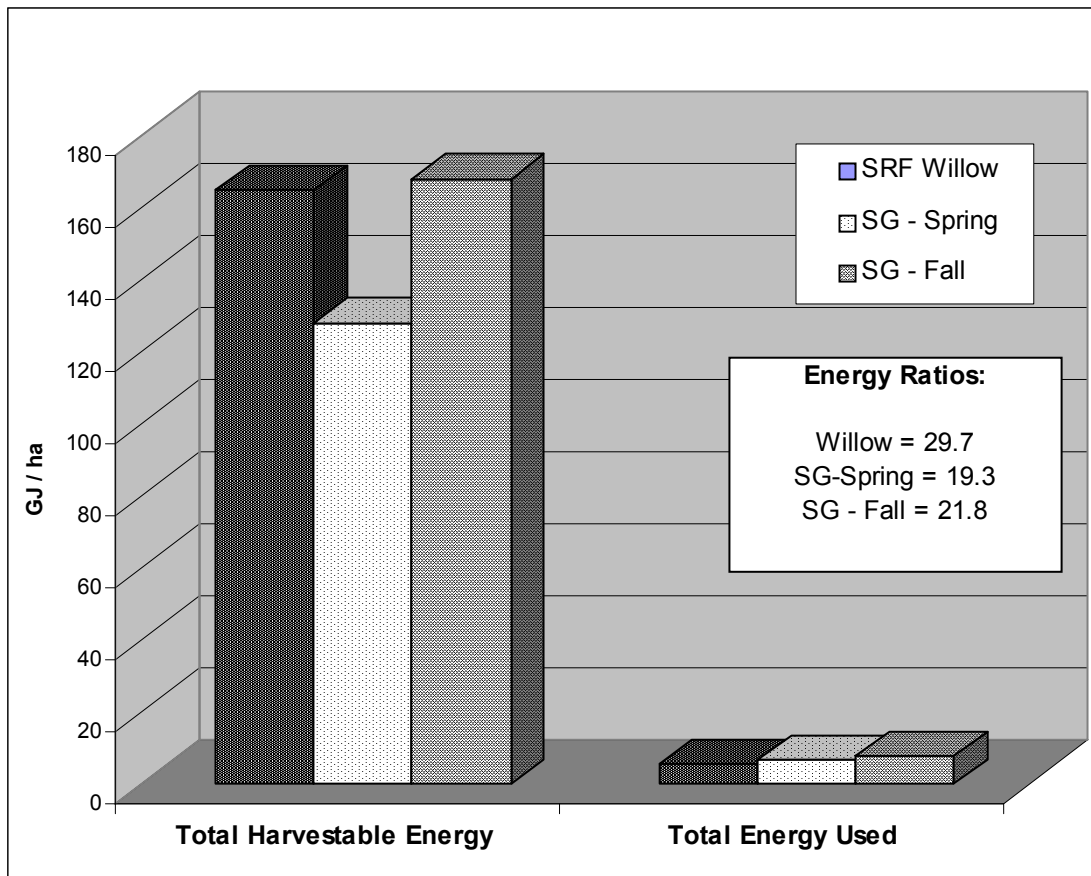

Figure 4.8. Energy Budget for Cropping Systems

To date, most of the field research on switchgrass in eastern Canada has focused on the spring harvest regime, which offers benefits in terms of nutrient demands, combustion characteristics and possibly on stand vigor. The drawback of this regime is the amount of biomass lost over winter. The material lost is of low value if used by the pulp and paper industry, but is likely to be well suited for ethanol manufacturing and other energy applications. Adding a second harvest period to switchgrass cultivation would increase the operating time of the harvesting equipment and reduce storage requirements, reducing the cost of the overall biomass supply system. The main factors requiring research before recommending the fall harvest system for eastern Canada are the effects of harvest dates and winter conditions on stand survival. Harvesting in the spring ensures a maximum translocation of nutrients to the roots in the fall and provides a winter-long mulch on the field, protecting the stands. Based on the models developed in this study, fall harvesting could reduce delivered costs by an average of 17%.

Overall, it can be concluded from this study that SRF willows and switchgrass grown in the study region should be at least neutral in terms of net atmospheric carbon gains/losses, which is a major advantage if these crops are later converted into biofuels.

SUMMARY AND CONCLUSIONS

5.1. Summary

The broad objective of this study was to develop economic, energy, and carbon emission budgets associated with the cultivation of switchgrass and SRF willow plantations grown as part of a CO₂ offset strategy.

A research protocol was developed in the first year, as well as literature reviews and field data collection on organic carbon storage in above and belowground plant biomass, and in the soil. Two five-hectare sites located in Ste-Anne-de-Bellevue, Quebec, were chosen to conduct the experiments. In 1996, grain corn was planted on plots adjacent to those of switchgrass and SRF willows (both planted in 1993) to measure the carbon storage potential of the perennial crops.

The average field productivity assessment (from Chapter 2) was evaluated on switchgrass (Cave-in-Rock), willow shoots (*Salix alba x glaufelteri*), and corn grain for both sites, these measurements were taken in order to investigate harvestable biomass. Yields, in 1996, of 12.3 odMg/ha for switchgrass, 7.1 odMg/ha for SRF willow, and 8.5 odMg/ha for corn were obtained. In 1997, field productivity averaged 12.6 odMg/ha for switchgrass, 8.4 odMg/ha for SRF willows, and approximately 6 odMg/ha for corn. In 1998, switchgrass harvestable biomass was 12.1 odMg/ha, SRF willows was 20.5 odMg/ha, and corn reached 8.0 odMg/ha.

The total aboveground biomass production (including litter, leaves, stems, weeds) for all plots of switchgrass, SRF willows (leaves and shoots) and corn (stalk/leaves, grain, cobs) was also measured (Chapter 3), to evaluate total aboveground yields, which were related to the amount of carbon storage in the landscape. In 1996, total annual aboveground biomass was estimated at 15.6, 13.5 and 16.2 odMg/ha, for switchgrass, willow and corn, respectively. In 1997, total annual aboveground biomass accumulations for switchgrass, SRF willow and corn, were 16.6, 19.0, and 13.0 odMg/ha, respectively. In 1998, the yields (not including litter and weeds) averaged 12.8, 18.2, and 19.8 odMg/ha for switchgrass, SRF willow and corn, respectively.

In terms of belowground biomass production in 1996, switchgrass and SRF willows were more productive than corn, with an average yield of 7.2 and 9.0 odMg/ha, respectively, versus 1.6 odMg/ha for corn.

In 1996, SRF willow was found to have an average aboveground C content of 46%, switchgrass had 45% and corn, 45%. The belowground C contents (including the root crowns for willow and corn) averaged 42%, 44%, 36% for SRF willow, switchgrass and corn, respectively.

The total average soil organic carbon storage under SRF willow, switchgrass and corn systems was 122 t/ha, 106 t/ha, and 106 t/ha, respectively, 4 years after establishment of the perennial crops, and one season after the establishment of the annual crop (corn). A second soil organic matter sampling from 0-60 cm in each plot was conducted in the fall of 1998, to obtain soil organic carbon values 6 years after plantation establishment. The total average soil organic carbon storage under SRF willow was 94 t/ha, whereas switchgrass stored 84 t/ha, and corn stored 83 t/ha.

With the above data, economic, energy and carbon budgets were developed (Chapter 4) for SRF willow and switchgrass cropping practices.

5.2. General Conclusions

- The study indicated that in 1996, SRF willows and switchgrass had greater soil organic carbon levels at the Ecomuseum site (more fertile site) than at the Seedfarm site (inherently less fertile site). In addition, both perennial crops at the more fertile site were able to sequester more soil carbon than the annual grain crop. This was not the case at the poorer site.
- At the more fertile site (Ecomuseum), the soil organic carbon accumulation rate from 1993 to 1996 was estimated to be 5.3 tonnes C/ha/yr for SRF willows using switchgrass soil carbon levels as a benchmark. Using corn soil carbon levels as a benchmark, switchgrass accumulated 3.8 tonnes C/ha/yr, and SRF willows accumulated 9 tonnes C/ha/yr.

- In 1998, at the Ecomuseum, although SRF willows sequestered 2.4 tonnes C/ha/yr more organic carbon than corn, and switchgrass sequestered 1.2 tonnes C/ha/yr more than the corn, soil organic carbon was not significantly different between the treatments. Likewise, at the Seedfarm, willows sequestered 0.3 tonnes C/ha/yr, compared to the corn, whereas switchgrass lost 1.3 tonnes C/ha/yr, compared to corn, however no treatment effects were found.
- Over time (4-6 years), soil organic carbon may decrease in SRF willow, switchgrass and corn cropping systems. The greatest loss was found in the 0-30 cm depth. The exact cause of this has not been studied, however the decrease may be related to fertilization levels in the perennial crops, as well as erosion taking place in the annual row crop plots.
- Corn was found to have a limited root biomass production compared to switchgrass and SRF willows. Switchgrass had significantly greater root biomass yields from 30-60 cm, compared to corn and willow, as well as a greater root biomass at 45-60 cm compared to a hardwood forest and a 20 year old abandoned field. Perennial grasses therefore, have the potential to sequester greater amounts of soil carbon deeper in the soil profile due to increased root carbon inputs.
- SRF willows and switchgrass were estimated to produce biomass with positive energy output:input ratios. Once delivered to a conversion facility, SRF willows had energy ratios of almost 30 while it varied between 19 and 22 for switchgrass, depending on the harvesting regime adopted. These ratios were equivalent to net energy gains per hectare of 159 GJ/ha and 122-160 GJ/ha, respectively.
- Without accounting for any carbon sequestration in either the soil or in the plant biomass, SRF willows and switchgrass were estimated to release 0.63 kg C and 0.86-0.95 kg C, respectively, to the atmosphere per Gigajoule of biomass energy produced, due to fossil fuel utilization during their production process.
- The minimum annual rate of soil carbon sequestration required to offset the fossil fuel emissions during the production cycle were estimated to be 104 kg C/ha and 121-144 kg C/ha for SRF willows and switchgrass, respectively.

- SRF willows were estimated to be more expensive to produce than switchgrass. For yields between 7-11 odMg/ha/yr, the delivered cost of SRF biomass was estimated to vary between \$58 and \$85/odMg. For switchgrass harvested in the fall (8-13 odMg/ha/yr), delivered costs were \$41-\$57/odMg. When switchgrass was harvested in spring (6-10 odMg/ha/yr) delivery costs were \$46-\$66/odMg. SRF willows are more expensive to produce than switchgrass but have a greater output:input energy ratio and a greater carbon sequestration potential.
- SRF willows and switchgrass have the potential to increase carbon storage by increasing soil organic carbon levels and/or carbon levels in their plant biomass. The level of carbon storage attainable for each crop should be sufficient to at least offset the carbon emissions released from the burning of fossil fuels during crop production, resulting in carbon neutral feedstocks. With proper site selection and cropping practices, the production of these feedstocks could produce viable carbon sinks.

5.3. Directions for Further Research

The project has brought forth a number of issues which require further investigation, namely:

- The need for continuous soil organic carbon monitoring, to quantify organic carbon level fluctuations, and determine the causes.
- The effect of different fertilizer rates on soil organic carbon accumulation under the SRF willow, switchgrass and corn cropping systems.
- The impact of establishing, and well-established, switchgrass fine roots on soil carbon levels at deeper layers. As well as the effects of coppicing and root turn over in willows, on soil carbon sequestration.
- The effect of soil organic carbon levels, and/or fertility levels, on fine root distribution and root turn over rates.
- To estimate the soil carbon equilibrium levels for switchgrass and SRF willows for soils in the study region, i.e. eastern Canada.

- To evaluate the carbon offset potential for the complete biofuel cycle, using switchgrass and SRF willows as feedstocks.
- To evaluate other potential greenhouse gas emissions (e.g. N₂O) in the production of biofuels using switchgrass and SRF willows.
- To evaluate the impact of greenhouse gas reduction strategies, such as tradable emission permits, upon the adoption of SRF willows and switchgrass by farmers and potential biofuel producers.

Bibliography

- Aber, J. D., Melillo, J. M. 1982. Nitrogen immobilization in decaying hardwood leaf litter as a function of nitrogen and lignin content. *Can. J. Bot.* 60:2263-2269.
- Allison, L.E. 1965. Soil Organic Matter and its Role in Crop Production. Madison, Wis.: Elsevir, Amsterdam. 637pp.
- Anderson, I.C., Buxton, D.R., Karlen, D.L., Cambardella, C. 1997. Cropping system effects on nitrogen removal, soil nitrogen, aggregate stability, and subsequent corn grain yield. *Agron. J.* 89:881-886.
- Arrouays, D., Pellisier, P. 1994. Changes in carbon storage in temperate humic loamy soils after forest clearing and continuous corn cropping in France. *Plant Soil* 160:215-223
- Balesdent, J., Balabane, M. 1996. Major contribution of roots to soil carbon storage inferred from maize cultivated soils. *Soil Biol. Biochem* 28:1261-1263
- Barker, J. R., Baumgardner, G. A., Turner, D. P., Lee, J. J. 1996. Carbon dynamics of the Conservation and Wetland Reserve Programs. *J. of Soil and Water Cons.* 51:340-346
- Bolin, B. 1986. How much CO₂ will remain in the atmosphere? The carbon cycle and projections for the future. In *The greenhouse effect, climatic change and ecosystems.*, ed. B. Bolin, B. R. Doos, J. Jager, R. A. Warrick. pp. 157-203. New York: Wiley & Sons
- Bolinder, M. A., Angers, D. A. 1997. Effets des cultures destinées à la production d'éthanol sur le bilan du carbone du sol dans l'est du Canada. Plan Vert du Canada: Programme Ethanol
- Bottner, P., Sallih, Z., Billes, G. 1988. Root activity and carbon metabolism in soils. *Biol. Fertil. Soils* 7:71-78
- Bouwman, A. F., Sombroek, W. G. 1990. Inputs to climatic change by soil and agriculture related activities. Present status and possible future trends. In *Soils on a Warmer Earth*, ed. H. W. Scharpenseel, M. Schomaker, A. Ayoub. pp. 15-30. Amsterdam: Elsevier Science Publishers B.V.
- Bransby, D.I., Mclaughlin, S.B., Parrish, D.J., 1998. A Review of Carbon and Nitrogen Balances in Switchgrass Grown for Energy. *Biomass and Bioenergy* 00:1-6.
- Bruce, J.P., Frome, M., Haites, E., Janzen, H., Lal, R., Paustian, K. 1999. Carbon sequestration in soils. *J. Soil Water Cons.* 54(1):382-389.
- Bryan, J. 1998, June 20. Renew and Profit: North America's alternative-energy industry comes of age. *Montreal Gazette*, p.G1.
- Burke, I.C., Lauenroth, W.K., Coffin, D.P. 1995. Recovery of soil organic matter and N mineralization in semiarid grasslands: Implications for the Conservation Reserve Program. *Ecological Applications* 5:793-801.

- Cambardella, C. A., Elliott, E. T. 1992. Carbon and nitrogen dynamics of soil organic matter fractions from cultivated grassland soils. *Soil Sci. Soc. Am. J.* 58:123-130
- Campbell, C.A., McConkey, B.G., Zentner, R.P., Selles, F., Curtin, D. 1996. Tillage and crop rotation effects on soil organic C and N in a coarse-textured Typic Hapliboroll n southwestern Saskatchewan. *Soil and Tillage Research* 37:3-14.
- Campbell, C.A., Selles, F., Lafond, G.P. McConkey, B.G., Hahn D. 1998. Effect of crop management on C and N in long-term crop rotations after adopting no-tillage management: Comparison of soil sampling strategies. *Can. J. Soil Sci.* 78:155-162.
- Campbell, C.A., Zentner, R.P. 1993. Soil organic matter as influenced by crop rotations and fertilization. *Soil Sci. Soc. Am. J.* 57:1034-1040.
- Carter, M. R. 1996. Analysis of soil organic matter storage in agroecosystems. In *Structure and organic matter storage in agricultural soils*, ed. M. R. Carter, B. A. Stewart. Boca Raton, Florida: CRC Press/Lewis Publishers
- Carter, M. R., Angers, D. A., Gregorich, E. G., Bolinder, M. A. 1997. Organic carbon and nitrogen stocks and storage profiles in cool, humid soils of eastern Canada. *Can. J. Soil Sci.* 77:205-210
- Chapin, F. S. I., Bloom, A. J., Field, C. B., Waring, R. H. 1987. Plant responses to multiple environmental factors. *BioScience* 37:49-57
- Cheng, W., Coleman, D. C. 1990. Effect of living roots on soil organic matter decomposition. *Soil Biol. Biochem.* 22:781-787
- Cole, C. V., Flach, K., Lee, J., Sauerbeck, D., Stewart, B. 1993. Agricultural sources and sinks of carbon. *Water, Air, and Soil Pollution* 70:111-122.
- CREAQ, 1987. Machinerie, AGDEX 740: Force requise, vitesse de travail et efficacité. Le Comité de Références Économiques en Agriculture du Québec: 7pp.
- CREAQ, 1987. Machinerie, AGDEX 765/821: Frais d'exploitation. Le Comité de Références Économiques en Agriculture du Québec: 7pp.
- CREAQ, 1994. Machinerie, AGDEX 740/825: Coûts et taux à forfait suggérés. Le Comité de Références Économiques en Agriculture du Québec. 12pp.
- Dalal, R.C. 1989. Long-term effects of no-tillage, crop residue, and nitrogen application on properties of a Vertisol. *Soil Sci. Soc. Am. J.* 53:1511-115.
- Dahlman, R.C., Kucera, C.L. 1965. Root productivity and turnover in native prairie. *Ecology* 46:84-89.
- Dewar, R.C., and Cannell, M.G.R. 1992. Carbon sequestration in the trees, products and soils of forest plantations: an analysis using UK examples. *Tree Physiology* 11:49-71.
- Doormar, J.F., Smoliak, S. 1985. Recovery of vegetative cover and soil organic matter during revegetation of abandoned farmland in a semi-arid climate. *Journal of Range Management* 38:487-491.

- Eghball, B., Binford G.D., Baltensperger, D. 1996. Phosphorus movement and adsorption in a soil receiving long-term manure and fertilizer application. *J. Environ. Qual.* 25:1339-1343.
- Eissenstat, D.M., Cladwell, M.M. 1988. Seasonal timing of root growth in favorable microsites. *Ecology* 69:870-873.
- Ellert, B.H., Bettany, J.R. 1995. Calculation of organic matter and nutrients stored in soils under contrasting management regimes. *Can J. Soil Sci.* 75:529-538.
- Elliott, E. T. 1986. Aggregate structure and carbon, nitrogen, and phosphorus in native and cultivated soils. *Soil Sc. Soc. Am. J.* 50:627-633.
- Emanuel, W. R., Killough, G. G., Post, W. M., Shugart, H. H. 1984. Modeling terrestrial ecosystems in the global carbon cycle with shifts in carbon storage capacity by land-use change. *Ecology* 65:970-983.
- Enriquez, S., Duarte, C. M., Sand-Jensen, K. 1993. Patterns in decomposition rates among photosynthetic organisms: the importance of detritus C:N:P content. *Oecologia* 94:457-471.
- Eswaran, H., Berg, E. V. D., Reich, P. 1993. Organic carbon in soils of the world. *Soil Sci. Soc. Am. J.* 57:192-194.
- Evans, P.S. 1997. Comparative root morphology of some pasture grasses and clovers. *N.Z. J. Agric. Res.* 20:331-335.
- Fisher, M. J., Rao, I. M., Ayarza, M. A., Lascano, C. E., Sanz, J. I., et al. 1994. Carbon storage by introduced deep-rooted grasses in the South American savannas. *Nature* 371:236-238.
- Ford-Robertson, J.B. 1997. Carbon balance calculations for forest industries-a review. *N.Z. Forestry* 42:32-36.
- Foster, H.L. 1981. The basic factors which determine inherent soil fertility in Uganda. *J. Soil Sci.* 32:149-160.
- Gebhart, D.L., Johnson, H.B., Mayeux, H.S., Polley, H.W. 1994. The CRP increases soil organic carbon. *J. Soil Water Cons.* 49(5):488-492.
- Girouard, P., Henning, J., John C., Samson, R., 1995. Economic Assesment of Short-Rotation Forestry and Switchgrass Plantations for Energy Production in Central Canada. *Proceedings of the Canadian Energy Plantation Workshop.* May 2-4, 1995. Gananoque, Ontario. p.11-16.
- Girouard, P., Walsh, M.E., Becker, D.A. 1999. BIOCOST-Canada : A new tool to evaluate the economic, energy, and carbon budgets of perennial energy crops. Fourth Biomass Conference of the Americas, Oakland, CA, Aug. 29-Sept. 2, 1999. [In press]

- Goel, K., Eisner, R., Sherson, G., Radiotis, T., Li, J., 1998. Switchgrass : a Potential Pulp Fiber Source. *Proceedings of the 84th Annual Meeting, Technical Section, Canadian Pulp and Paper Association*. January 29-30, 1998 :B109-B114.
- Goudriaan, J., Dirks, B. 1996. Uptake and release of CO₂ by grassland. *Change* 31:3-6
- Gregorich, E. G., Ellert, B. H., Angers, D. A., Carter, M. R. 1995. Management-induced changes in the quantity and composition of organic matter in soils of eastern Canada. In *Prospects for carbon sequestration in the biosphere*, ed. M. Beran. pp. 273-283. Berlin, Germany: NATO ASI, Springer-Verlag
- Grigal, D.F., Berguson, W.E. 1998. Soil carbon changes associated with short-rotation systems. *Biomass and Bioenergy* 14:371-377.
- Hagenstein, P.R. 1996. Management strategies for hardwood forests to increase carbon storage and reduce carbon emissions. In: *Forests and Global Change. Forest Management opportunities for Mitigating Carbon Emissions*, ed. R.N. Sampson, D. Hair. Pp. 181-188. Vol 2. Washington, DC: American Forests.
- Hansen, E.A. 1993. Soil carbon sequestration beneath hybrid poplar plantations in the north central United States. *Biomass and Bioenergy* 5(6):431-436.
- Helal, H. M., Sauerbeck, D. R. 1984. Influence of plant roots on C and P metabolism in soil. *Plant and Soil* 76:175-182.
- Hendrickson, O.Q. and Robinson, J.B. 1984. Effects of roots and litter on mineralization processes on forest soil. *Plant Soil* 80:391-405.
- Hill, S., Nault, J., 1995. Towards a More Energy Efficient Cash Crop Farm. *Sustainable Farming*, Fall 1995 :8-11.
- Houghton, R.A. Hobbie, J.E., Melillo, J.M. Moore, B., Peterson, B.J., Shaver, G.L., Woodwell, G.M. 1983. Changes in the carbon content of terrestrial biota and soils between 1860 and 1980. A net release of CO₂ to the atmosphere. *Ecol. Monographs* 53:235-262.
- IPCC (Intergovernmental Panel on Climate Change). 1995. Climate Change 1995: The Science of Climate Change. Contribution of Working Group I to the Second Assessment Report of the Intergovernmental Panel on Climate Change. Houghton, J.T., Meira Filho, L.G., Callander, B.A., Harris, N. Kattenberg, A., Maskell, K. (Eds.) Cambridge University Press, Cambridge.
- IPCC (Intergovernmental Panel on Climate Change). 1992. Climate Change 1992. Report to the IPCC Scientific Assessment: Cambridge University Press, Cambridge.
- Jastrow, J.D. 1996. Soil aggregate formation and the actual of particulate and mineral-associated organic matter. *Soil Biology and Biochemistry* 28:665-676.
- Jones, M. J. 1973. The organic matter content of the Savannah soils of West Africa. *J. Soil Sci.* 24:42-53.

- Kuikman, P.J., Lekkerkerk, L.J.A., VanVeen, J.A. 1991. Carbon dynamics of a soil planted with wheat under an elevated atmospheric CO₂ concentration. In *Advances in Soil Organic Matter Research: The Impact on Agriculture & the Environment*, ed. W. S. Wilson The Royal Society of Chemistry
- Kürsten, E. and Burschel, P. 1993. CO₂-Mitigation by agroforestry. *Water, Air, and Soil Pollution* 70:533-544
- Labrecque, M., Teodorescu, T.I. 1998. Les terres abandonnées et les cultures d'arbres sur courts rotations: une conjoncture favorable pour l'énergie. In: *Bioenergy Technical Session 3. Solar Energy Society of Canada*. Ottawa. Pp 59-66.
- Lajoie, P. G. 1960. *Soil Survey of Argenteuil, Two Mountains and Terrebonne Counties, Quebec*. Research Branch, Canada Department of Agriculture in co-operation with Quebec Department of Agriculture and Macdonald College, McGill University.
- Lal, R., Follett, R.F., Kimble, J., Cole, C.V. 1999. Managing U.S. cropland to sequester carbon in the soil. *J. Soil Water Cons.* 54(1):374-381.
- Larson, W. E., Clapp, C. E., Pierre, W. H., Morachan, Y. B. 1972. Effects of increasing amounts of organic residues on continuous corn: II. Organic carbon, nitrogen, phosphorus and sulfur. *Agron. J.* 64:204-208.
- Lepsch, I. F., Menk, J. R. F., Oliveira, J. B. 1994. Carbon storage and other properties of soils under agriculture and natural vegetation in Sao Paulo, Brazil. *Soil Use and Management* 10:34-42
- Liang, B. C., Mackenzie, A. F. 1992. Changes in soil organic carbon and nitrogen after six years of corn production. *Soil Science* 153:307-313
- Linden, D. R. and Clapp, C.E. 1998. Effect of corn and soybean residues on earthworm cast carbon and natural abundance isotope signature. In: *Soil Processes and the Carbon Cycle*, ed. R. Lal, J.M. Follett, B.A. Stewart. Pp. 345-31. Boca Raton: CRC Press.
- Lindstrom, M.J. 1986. Effects of residue harvesting on water runoff, soil erosion and nutrient loss. *Agric. Ecosys. Environ.* 16: 103-112.
- Malhi, S.S., Nyborg, M., Harapiak, J.T., Heier, K., Flore N.A. 1997. Increasing organic C and N in soil under brome grass with long-term N fertilization. *Nut. Cycl. Agroecosyst.* 49:225-260
- Marinissen, J.C.Y., Didden, W. A. M. 1997. Influence of the enchytraeid worm *Buchholzia appendiculata* on aggregate formation and organic matter decomposition.
- Marland, G. and Thurhollow, A., F., 1991. CO₂ Emissions from the Production and Combustion of Fuel Ethanol from Corn. Environmental Science Division, Oak Ridge National Laboratory, Tennessee: 8pp.
- Mouat, M.C.H. 1983. Competitive adaptation of plants to nutrient shortage through modification of root growth and surface charge. *N.Z. J. Agric. Res.* 26:327-332.

National Energy Board. Canadian Energy Supply and Demand 1990-2010. Canada, June 1991: 70pp.

Nilsson, L.O., Ericsson, T. 1985. Influence of shoot age on growth and nutrient uptake patterns in a willow plantation. *Can J. For. Res.* 16:185-190.

Nyborg, M., Molina-Ayala, M., Solberg, E.D., Izaurralde, R.C., Malhi, S.S., Janzen, H.H. 1998. *In Management of Carbon Sequestration in Soil.* Lal, R., Kimble, J.M., Follett, R.F., Stewart, B.A. (Eds.) Carbon storage in grassland soils as related to N and S fertilizers. Chapter 29, pp. 421-430.

Oades, J.M. 1995. An overview of processes affecting the carbon cycling of organic carbon in soils. In: *The Role of Non-Living Organic Matter in the Earth's Carbon Cycle.*, ed. R.G. Zepp, C. Sonntag. Pp. 293-303 Dahlem Workshop Reports, John Wiley, New York.

Parton, W. J., Cole, C. V., Stewart, J.W.B., Ojima, D. S., Schimel, D. S. 1989. Simulating regional patterns of soil C, N, and P dynamics in the U.S. central grasslands region. In: *Ecology of Arable Land.*, ed. M. Clarholm, L. Bergstrom. Pp. 99-108 Kluwer Academic Publishers, New York.

Paustian, K., Parton, W. J., Persson, J. 1992. Modeling soil organic matter in organic-amended and N-fertilized long-term plots. *Soil Sci. Soc. Am. J.* 56:476-488

Paustian, K., Robertson, G. P., Elliot, E. T. 1995. Management impacts on carbon storage and gas fluxes (CO₂, CH₄) in mid-latitude cropland. In *Advances in Soil Science. Soil management and greenhouse effect*, ed. R. Lal, J. Kimble, E. Levine, B. A. Stewart. pp. 69-83. Boca Raton, Florida: CRC Press, Inc.

Paustian, K., Andr n, O., Janzen, H.H., Lal, R., Smith, P., Tian, G., Tiessen, H., Van Noordwijk, M., Woerner, P.L. 1997. Agricultural soils as a sink to mitigate CO₂ emissions. *Soil Use and Management* 13:230-244.

Pennock, D. J., Kessel, C. V. 1997. Effect of agriculture and of clear-cut forest harvest on landscape-scale soil organic carbon storage in Saskatchewan. *Can. J. Soil Sci.* 77:211-218.

Ranney, J.W., Wright, L.L., Mitchell, C.P. 1991. Carbon storage and recycling in short rotation energy crops, In: *Bioenergy and the Greenhouse Effect, Proc. of a Seminar Organized by International Energy Agency/Bioenergy Agreement and National Energy Administration of Sweden.* NUTUK B 1991:1., ed C.P. Mitchell. pp. 39-59. Stockholm, Sweden.

Rasmussen, P.E., Parton W.J. 1994. Long-term effects of residue management in wheat-fallow: I. Inputs, yield, and soil organic matter. *Soil Sci. Soc. Am. J.* 58:523-530.

Rasmussen, P.E., Albrecht, S.L. 1998. Crop management effects on organic carbon in semi-arid Pacific Northwest soils. In: *Management of Carbon Sequestration in Soil*, ed. R. Lal, J.M. Kimble, R.F. Follett, B.A. Stewart. pp. 195-208. Boca Raton: CRC Press.

- Rehfuess, K.E., Rosch, I., Makeschin, F. 1990. Short rotation plantations in central Europe: Nutrition and influences on soil factors. In: *XIX World Congress. Science in Forestry: IUFRO's Second Century*. pp. 214-220 Vol 1. Montreal, Canada.
- Richter, D.D., Babber, L.I., Huston, M.A., Jaeger, M. 1990. Effects on annual tillage on organic carbon in a fine-textured udalf: the importance to root dynamics to soil carbon storage. *Soil Science* 149:78-83.
- Rubin, E. S., Cooper, R. N., Frosch, R. A., Lee, T. H., Marland, G., et al. 1992. Realistic mitigation options for global warming. *Science* 257:148-166
- Rytter, R.-M. 1997. Fine-root production and carbon and nitrogen allocation in basket willows. Doctoral Thesis. Swedish University of Agricultural Sciences. Uppsala, Sweden.
- Sallih, Z., Bottner, P. 1988. Effect of wheat (*Triticum aestivum*) roots on mineralization rates of soil organic matter. *Biol. and Fert. of Soils* 7:67-70
- Samson, R., Girouard, P., Chen, Y., Quinn, J. 1995. Technology Evaluation and Development of Short Rotation Forestry for Energy Production. Volume 1. Final Report. Presented to the Bioenergy Development Program. pp.215
- Schimel, D. S. 1995. Terrestrial ecosystems and the carbon cycle. *Global Change Biology* 1:77-91
- Schimel, D. S., Braswell, B. H., Holland, E. A., McKeown, R., Ojima, D. S., et al. 1994. Climatic, edaphic, and biotic controls over storage and turnover of carbon in soils. *Global Biogeochem. Cycles* 8:279-293
- Scurlock, J. M. O., Hall, D. O., House, J. I. 1993. Utilizing biomass crops as an energy source: a European perspective. *Water, Air, and Soil Pollution* 70:499-518
- Singh, B.R., Borresen, T., Uhlen, G., Ekeberg, E. 1998. Long-term effects of crop rotation, cultivation practices, and fertilizers on carbon sequestration in soils in Norway. In: *Management of Carbon Sequestration in Soil*, ed. R. Lal, J.M. Kimble, R.F. Follett, B.A. Stewart. pp. 195-208. Boca Raton: CRC Press.
- Smith, W. N., Rochette, P., Monreal, C., Desjardins, R. L., Pattey, E., Jacques, A. 1997. The rate of carbon change in agricultural soils in Canada at the landscape level. *Can. J. Soil Sci.* 77:219-229.
- Solberg, E.D., Nyborg, M. Izaurralde, R.C., Malhi, S.S., Janzen, H.H. Molina-Ayala, M. 1988. Carbon storage in soils under continuous cereal grain cropping: N fertilizer and straw. In: *Management of Carbon Sequestration in Soil*, ed. R. Lal, J.M. Kimble, R.F. Follett, B.A. Stewart. Pp. 235-254. Boca Raton: CRC Press.
- Sollins, P., Spycher, G., Glassman, C.A. 1984. Net nitrogen mineralization from light- and heavy-fraction forest soil organic matter. *Soil Biol. Biochem.* 16:31-37.
- Sowden, F.J., Atkinson, H.J. 1968. Effect of long-term annual additions of various organic amendments on the organic matter of clay and a sand. *Can. J. Soil Sci.* 48:323-330.

- Stevenson, F. J. 1986. *Cycles of Soil* A Wiley-Interscience Publication. John Wiley & Sons, Inc.
- Taylor, B. R., Parkinson, D., Parsons, W. F. J. 1989. Nitrogen and lignin content as predictors of litter decay rates: a microcosm test. *Ecology* 70:97-104
- Tisdall, J. M., Oades, J. M. 1982. Organic matter and water-stable aggregates in soil. *J. Soil Sci.* 33:141-163.
- Transport Canada, 1996. Operating Costs of Trucks in Canada – 1996. Motor Carrier Policy, Transport Canada. http://www.tc.gc.ca/trucking/OpCosts1996/introlb_e.htm: Final Report.
- Transport Canada, 1996. Quebec Cases. Motor Carrier Policy, Transport Canada. http://www.tc.gc.ca/trucking/OpCosts1996/introlb_e.htm: Canadian Costs by Province.
- UNFCCC (United Nations Framework Convention on Climate Change). 1997. *Kyoto Protocol to the United Nations Framework Convention on Climate Change: English Conference of the Parties- Third Session, 1-10 December, Kyoto, Japan.*
- Van Cleve, K., Moore, T.A. 1978. Cumulative effects of nitrogen, phosphorus, and potassium fertilizer additions on soil respiration, pH, and organic matter content. *Soil Sci. Soc. Am. J.* 42:121-124.
- Van den Pol van dasselaar, A., Lantinga, E. A. 1995. Modeling the carbon cycle of grassland in the Netherlands under various management strategies and environmental conditions. *Netherlands Journal of Agricultural Science* 43:183-194
- Van Veen, J. A., Paul, E. A. 1981. Organic carbon dynamics in grassland soils. 1. Background information and computer simulation. *Can. J. Soil Sci.* 61:185-201.
- Vogt, K.A., Vogt, D.J., Brown, S., Tilley, J.P., Edmonds, R. L., Silver, W.L., Siccama, T.G. 1995. Dynamics of forest floor and soil organic matter accumulation in boreal, temperate, and tropical forests. In *Soil Management and Greenhouse Effect*, ed. R/ Lal, J. Kimble, E. Levine, B.A. Stewart. pp. 159-178. Boca Raton: Lewis Publishers.
- Weaver, J. E. 1968. *Prairie plants and their environment* Lincoln: University of Nebraska Press. 276 pp.
- Willebrand, E. 1995. Cutting Cycle Length of Short Rotation Forests – Swedish Country Report. In *Handbook on How to Grow Short Rotation Forests* (Ledin, S. and A. Alriksson, ed.). Swedish University of Agricultural Sciences.
- Wright, L.L., Hughes, E.E. 1993. U.S. carbon offset potential using biomass energy systems. *Water, Air, and Soil Pollution* 70:483-497.
- Yeomans, J. C., Bremner, J. M. 1988. A rapid and precise method for routine determination of organic carbon in soil. *Commun. in Soil Sci. Plant Anal.* 19:1467-1476

Zan, C. 1998. Carbon Storage in Switchgrass (*Panicum virgatum* L.) and Short-Rotation Willow (*Salix alba* x *glauca* L.) Plantations in Southwestern Quebec. [MSc. Thesis]. Montreal (QC): McGill University; 108p.

Appendix 1

Cropping Practices for SRF Willows, Switchgrass, and Corn

A1.1.1. Cropping Practices for SRF Willows

Seedfarm	1993	1994	1995	1996	1997	1998
Operation	May 11, Cultivated (2x)					
Tillage	May 12-23, 11 000 cuttings per ha, 0.92m row spacing					
Planting						
Coppicing				January, thinning saws used to coppice		
Mechanical weed control	May 17 and May 26, rotary hoe (2x) June 11, rotary hoe (1x) July 1, July 12, inter-row cultivation					
Herbicide	July 5, 1.54 L/ha quizalofop-ethyl + 2 L/ha oil surfactant (Assist)	1.54 L/ha quizalofop-ethyl + 2 L/ha oil surfactant (Assist)		July 3, 1996 quizalofop-ethyl		
Fertilization	June 10 60kg N/ha 70kg K/ha	June 10 60kg N/ha 70kg K/ha	June 17 77 kg N/ha 84 kg K/ha	June 17 77 kg N/ha 84 kg K/ha	July 7 125 kg N/ha 31 kg P/ha 75 kg K/ha	
Fall harvest	Dec 7 4 x 5m rows	Dec 7 4 x 5m rows	Dec 5 4 x 5m rows	Dec 9 4 x 5m rows	Dec 16 4 x 5m rows	Dec 3 4 x 5m rows

A1.1.2. Cropping Practices for SRF Willow

Ecomuseum	1993	1994	1995	1996	1997	1998
Operation	May 9 (reps 4-6), May 18 (reps 1-3) Cultivated (2x)					
Tillage						
Planting	May 9-11 (reps 4-6), May 19 (reps 2-3), May 21 (rep1) 11 000 cuttings/ha					
Coppicing				January, thinning saws used to coppice		
Mechanical weed control	May 17 (reps 1-3), May 26, Rotary hoe (2x) June 11, Rotary hoe (1x) July 1, July 13, Inter row cultivation					
Herbicide	July 5, 1.54 L/ha quizalofop-ethyl + 2 L/ha oil surfactant (Assist)					
Fertilization				June 17, 77 kg N/ha 84 kg K/ha	July 8, 125 kg N/ha 31 kg P/ha 75 kgK/ha	
Fall harvest		Dec 7 10 trees/plot	Dec 6 4 x 5m rows	Dec 9 4 x 5m rows	Dec 16 4 x 5m rows	Dec 3 4 x 5m rows

A1.2.1. Cropping Practices for Switchgrass

Seedfarm site	1993	1994	1995	1996	1997	1998
Operation	June 14, Disking and harrowing					
Seeding	June 14-15, 6 kg/ha density Brillion seeder					
Herbicide	July 5, 3 L/ha bentazon/atrazine and 2 L/ha oil surfactant (Assist)					
Straw removal		May 18	May 22	May 25-28	May 24-28	May 20
Spring yield assessment (4 x 1m ² quadrat)				May 15-16	May 20	May 7
Fall yield assessment (4 x 1m ² quadrat)		October 24	October 23	October 18	October 31	October 7
Fertilization	June 6 45 kg N/ha as urea	June 6 45 kg N/ha as urea	June 6 50 kg N/ha as urea	June 14 45kg N /ha as urea	June 10 75 kg N/ha as urea	June 5 50 kg N/ha as urea

A1.2.2. Cropping Practices for Switchgrass

Ecomuseum	1993	1994	1995	1996	1997	1998
Operation	June 14, Disking and harrowing					
Seeding	June 14-15, 6 kg seed/ha Used a Brillion seeder					
Herbicide	July 6, 3 L/ha bentazon/atrazine 2 L/ha oil surfactant (Assist)					
Mowing	August 1					
Straw removal		May 18	May 22	May 25-28	May 24-28	May 20
Spring yield assessment (4 x 1m ² quadrat)				May 17	May 21	May 7
Fall yield assessment (4 x 1m ² quadrat)		October 27	November 13	October 18	October 31	October 7
Fertilization		June 22 30 kg N/ha as ammonium nitrate	June 6 50 kg N/ha as urea	June 19 45 kg N/ha as urea	June 10 50 kg N/ha as urea	June 5 50 kg N/ha as urea

A1.3.1. Cropping Practices for Corn

Seedfarm	1993	1994	1995	1996	1997	1998
Operation						
Tillage		May 4, Disked and harrowed		May, disking (2x)	May, harrowing	May, disking (2x)
Seeding	Fallow	May 5-6, 12 500 willow cuttings per ha		May 29, Pioneer 3921 80 000 plants/ha 0.76 m rows Conventional 4 row corn planter	May 26, Pride K205 80 000 plants/ha 0.76 m rows Conventional 4 row corn planter	May 15, Pioneer 3893 80 000 plants/ha 0.76 m rows Conventional 4 Row corn planter
Mechanical weeding		May 19, and May 24, rotary hoeing (2x), and (1x) respectively		June 14, Interrow cultivation		
Chemical herbicide	Non selective roundup	May 19, 2 kg/ha simazine. 1.54 L/ha quizalofop-ethyl and 2 L/ha Assist, reps 4 & 6		2 L/ha metolachlor 3 L/ha dicamba/ atrazine	2 L/ha metachlor 3.7 L/ha dicamba/ atrazine	May 16, 1.25 L/ha dimethenamid and 4.4 L/ha dicamba/ atrazine June 9, 2 L/ha bentazon
Fertilization	None			May 29 & June 14 205 kg N/ha, 104 kg P/ha, 62 kg K/ha	May 22-26 162 kg N /ha, 104 kg P/ha, 66 kg K /ha	May 14 139 kg N/ha (urea) 66 kg K/ha May 15 23 kg P/ha 9 kg N/ha
Harvesting		Mid July , willows mowed and plowed due to pest infestations		October, 8 row header corn combine, and plowed	October, 8 row header corn combine, and plowed	October, 8 row header corn combine. November 3, offset disked
Corn yield Assessment				October 7 4 x 5m rows	October 7 4 x 5m rows	September 29 4 x 5 m rows

A1.3.2. Cropping Practices for Corn

<i>Ecomuseum</i>		1993	1994	1995	1996	1997	1998
Operation							
Tillage			May 10 (reps 4-6), disking and harrowing; May 19 (rep 3), disking and harrowing		May, disking (2x)	May, disking	May, disking (2x)
Seeding	Oil seed radish	May 10-11 (reps 4-6), May 20 (rep 3) June 7, 8 (reps 1,2) 12, 500 seeds/ha			May 29, Corn Pioneer 3921 4 row planter 80 000 seeds/ha	May 26, Corn Pride K206 4 row planter 80 000 seeds/ha	May 15, Pioneer 3893 80 000 plants/ha 0.76 m rows Conventional 4 Row corn planter
Mechanical weeding		May 20, May 24, rotary hoeing (2x) June 13- Inter row cultivation			June 14, inter row cultivation		
Herbicide		May 19 (reps 4-6), 2 kg/ha simazine, June 1 (rep 3), 2 L/ha June 10 (reps 1,2) Glyphosate + 2 kg/ha simazine			2 L/ha metachlor 3.7 L/ha dicamba/ atrazine (Marksman)	2 L/ha metachlor, 3.7 L/ha dicamba/ atrazine (Marksman)	May 16, 1.25 L/ha dimethenamid and 4.4 L/ha dicamba/ atrazine June 9, 2 L/ha bentazon
Fertilization	none				161 kg N/ha, 104 kg P/ha, 62 kg K/ha	176 kg N/ha, 104 kg P/ha, 66 kg K/ha	May 14 139 kg N/ha (urea) 66 kg K/ha May 15 23 kg P/ha 9 kg N/ha
Fall harvest				Mid July Mowed trees due to pest infestations	October, 8 row header corn combine, and plowed	October, 8 row header corn combine, and plowed	October, 8 row header corn combine. November 3, offset disked
Corn yield assessment					October 7 4 x 5m rows	October 7 4 x 5m rows	September 29 4 x 5 m rows

Appendix 2

Literature Review for Carbon Storage Study

A2. Literature Review

Global concern over increasing carbon dioxide (CO₂) concentrations in the atmosphere, possibly modifying climate patterns, has prompted research into the specific role that terrestrial ecosystems may play in global carbon cycling. The concentration of the greenhouse gas, CO₂, in the atmosphere is increasing at a rapid rate (Barker et al., 1996). The main sources responsible for this increase are the combustion of fossil fuels as well as land use changes (Barker et al., 1996). For instance, emissions of CO₂ in 1990 were 6.0 GtC from fossil fuel burning and approximately 1.6 GtC from deforestation (Bouwman and Sombroek, 1990; IPCC, 1992). The atmospheric CO₂ concentration, which contributes up to 65% to the global warming potential on a worldwide basis, is increasing steadily. It has increased from about 280 parts per million (ppm) at the beginning of the industrial revolution to about 360 ppm today (Smith et al., 1997; Goudriaan and Dirks, 1996; Schimel, 1995). Currently, the rate of increase in the atmospheric concentration of CO₂ is equivalent to 3.8 GtC/yr (Goudriaan and Dirks, 1996). It has been predicted that greenhouse gases will contribute to an average global temperature rise of 0.2 to 0.5°C per decade over the next 100 years, with CO₂ accounting for 50% of this increase (Barker et al., 1996).

With atmospheric CO₂ concentrations increasing at a rate of 0.5 % annually, and contributing to global warming (Bolin, 1986), there is much research impetus to accurately estimate the various components of the global carbon cycle (Van den Pol van dasselaar and Lantinga., 1995). In addition, Canada, among other nations, has agreed to reduce greenhouse gas emissions by the year 2008-2012 (UNFCCC, 1997). Hence, strategies to reduce CO₂ emissions into the atmosphere, such as the replacement of fossil fuels with renewable energy sources, such as biomass, and the storing of additional carbon into terrestrial carbon sinks, need to be fully assessed and further developed.

A2.1. Soil Organic Matter

All soils contain carbon in the form of organic matter. There is a large variability in the amounts of carbon from one soil to another, with organic carbon content being as low as 1% or less in coarse-textured soils, such as sands, to as much as 3.5%, often found in prairie grassland soils (Stevenson, 1986). The amount of organic matter usually decreases with soil depth (Arrouays and Pelissier, 1994; Stevenson, 1986).

The level of organic matter in the soil is dependent on an equilibrium between soil oxidation and annual soil carbon inputs (Bolinder and Angers, 1997). Soil organic matter acts as a reservoir for plant nutrients and plays a major role in stabilizing the soil structure (Allison, 1965; Gregorich et al, 1995). Organic matter maintains the quality and productivity of agricultural soils, and is also a very important reservoir of carbon, thus playing an essential role in carbon cycling (Bolinder and Angers, 1997). Typically, organic matter is assumed to have a 58% carbon content.

The main pool of terrestrial carbon is found in the soil (Goudriaan, 1995). The amount of carbon that is stored in the soil is threefold greater than amounts found in aboveground and root biomass and two-fold greater than that found in the atmosphere (Eswaran et al., 1993). Simply stated, soil organic matter is the net inter phase between carbon accumulation and decomposition processes. These processes are influenced by several factors including land use and management, productivity, soil type, topography, and climate.

A2.1.1 Factors Affecting Soil Organic Carbon Levels

Organic carbon accumulates from plant and animal debris, and atmospheric C input, in soils until an equilibrium is reached. Organic matter levels increase rapidly during the first few years of soil formation, then slow down to achieve an equilibrium level characteristic of the environment under which the soil was formed (Stevenson, 1986). This equilibrium level is controlled by factors affecting soil formation including climate, topography, vegetation, biota, parent material, and age or time. As a result, there can be great variability in the organic carbon content of soils, even in a very localized area (Stevenson, 1986). Other critical factors such as vegetation or crop type, as well as the specific land use or agricultural management system in place can have a major impact on soil organic matter accumulation (Carter, 1996). Moreover, factors such as soil particle size, pH, quantity and type of clay minerals, and subsurface drainage can also influence soil organic matter accumulation and storage.

A2.1.1.1 Soil Texture and Physical Protection

Several reasons have been given for the resilience of organic matter in soil. Firstly, organic colloids such as humic acids that resist attack by microorganisms are produced. Secondly, some organic matter interacts with mineral matter, allowing it to be protected from decomposition. Lastly, the quantity of stable organic matter formed is also dependent on amounts of essential nutrients (N, P, S) (Stevenson, 1986; Van Veen and Paul, 1981).

The process of soil formation leads to the movement of some organic carbon to deeper soil levels, usually through its association with clay or metal ions, as well as through leaching, and with soil organisms. Earthworms, for instance, can completely mix soil and transport organic matter to depths of approximately one meter. This movement of organic matter into the lower soil horizons continues even after equilibrium levels have been attained in the surface layers. Eventually, equilibrium will be reached in the deeper layers (Stevenson, 1986). The distribution of carbon usually decreases deeper in the soil profile, and often, a mathematical pattern of carbon distribution with depth can be established. This vertical pattern can also be used for modeling purposes (Arrouays and Pelissier 1994).

Parent material affects the carbon content of the soil through its influence on soil texture. Physical protection of soil organic matter due to its intimate associations with clay particles and soil aggregates has been shown to play a significant role in restricting microorganisms and extracellular enzymes from attaining the protected organic carbon, consequently reducing decomposition rates (Paustian et al., 1995; Elliott, 1986; Stevenson, 1986; Tisdall and Oades, 1982). This explains why fine-textured soils, such as clay, typically have higher organic carbon contents than loamy soils, which in turn have higher carbon contents than sandy soils. (Stevenson, 1986).

Much research has been carried out on the effect of clay contents on soil organic carbon storage (Pennock and Kessel, 1997; Paustian et al., 1995; Schimel et al., 1994; Tisdall and Oades, 1982; Van Veen and Paul, 1981). High clay contents in soil contribute to the chemical stability of organic residues through aggregations, and also help increase the moisture-holding capacity of soils (Pennock and Kessel, 1997; Schimel et al., 1994). Moreover, these factors help to increase the amount of organic residues added to the soil, and decrease their decomposition rates. For example, a modeling study of the northern United States, predicted a doubling of soil organic carbon storage from sandy soil to fine-textured or clay soils (Parton et al., 1989 in Pennock and Kessel, 1997).

The extent of the protection of organic matter varies with the degree of soil aggregation and clay content (Van Veen and Paul, 1981). For instance, a model by Van Veen and Paul (1981) estimated that under grassland conditions, 50% of the organic matter was considered to be protected. However, under cultivation the amount of protected organic matter was reduced to

20% for surface layers and to 40% for lower layers. Therefore, the disruption of aggregates may lead to an increase in both carbon and nitrogen mineralization.

Studies in São Paulo, Brazil have also shown that organic carbon in cultivated top soils is correlated with clay or clay/silt contents (Lepsch et al., 1994). Strong correlations between organic carbon and soil texture have also been found in Africa (Jones, 1973 and Foster, 1981 in Lepsch et al., 1994).

Nonetheless, some experiments have shown that clay content does not always control the amount of stored organic carbon (Gregorich et al., 1995). In an experiment comparing forest and adjacent cultivated sites for different soils in eastern Canada, Gregorich et al. (1995) found overall soil carbon storage and percent clay content to be poorly correlated. Rather, soil carbon was especially related to soil management, in addition to soil silt content.

A2.1.1.2 Climate

Climate is a predominant factor affecting plant distribution, amount of plant material produced, and the intensity of microbial activity in the soil. As a result, climate plays an important role in determining soil organic matter levels (Stevenson, 1986). Since soil carbon dynamics are site-specific, organic carbon storage should be expressed within well defined climatic regions. For instance, grassland soils typically have greater organic matter contents than other well-aerated soils, whereas deserts and some tropical soils have some of the lowest levels. Typically, soils of very warm climates will have very low carbon contents (Stevenson, 1986).

It has been demonstrated that organic carbon storage increases within increasing precipitation and decreasing temperature (Carter et al., 1997). As temperature increases, the activities of microbial organisms will increase, leading to an increase in decomposition.

Frequent and abrupt changes in the environment, such as changes in humidity levels and temperature, have been shown to lead to ideal soil conditions for the production and preservation of organic matter. Hence, soils formed in harsh continental climates should have high carbon contents (Stevenson, 1986).

Increased rainfall causes increased plant growth and produces larger quantities of raw material for organic matter formation. The quantity of plant material that is returned to the soil can vary

from very limited amounts in arid and arctic regions to very large amounts in warm regions (Stevenson, 1986). Cool, humid soils tend to accumulate large amounts of organic matter. Wet, cool climates lead to good crop productivity, and therefore fairly large carbon inputs to the soil, and fairly slow organic matter turnover, which favors soil organic matter accumulation (Carter et al., 1997).

Since organic matter storage is regulated by carbon inputs and carbon losses (through decomposition), temperature and precipitation play a significant role in affecting soil organic matter accumulation.

A2.1.1.3 Topography

Topography also affects soil carbon by influencing climate, runoff, evaporation, and transpiration, even at a local level. For instance, soils occurring in depressions have higher carbon contents, due to the increased moisture, compared to those occurring on knolls, where it is drier. Typically, moist and poorly drained soils are usually high in organic matter, since anaerobic conditions will reduce microbial activity, and therefore prevent the oxidation of organic matter (Stevenson, 1986). Losses of organic matter can also be caused by erosion or runoff. Large losses of organic matter can occur due to a single very heavy rain storm or snowmelt (Van Veen and Paul, 1981).

A2.1.2 Residue Inputs and Decomposition Rates

The decomposition rates of soil carbon and crop residues are controlled by a variety of factors including soil abiotic conditions, residue quality and quantity, and soil disturbance. All these factors are potentially affected either directly or indirectly by management practices.

Different chemical compounds in plant materials vary in their decomposition rates, and in their lignin contents. Studies have shown that lignin contents of plant tissue often correlate well with litter decomposition rates. (Aber and Melillo, 1982; Paustian et al., 1995). The complex structure of lignin has limited the amount of organisms which are able to decompose it (Paustian et al., 1995).

A study by Van Veen and Paul (1981) on the decomposition rates of plant residues from grasslands demonstrated that cellulose and hemicellulose were easily decomposed by the soil microbial biomass, whereas the lignin fraction of the aboveground residues and roots were

transformed to resistant organic matter. The study also demonstrated that both the decomposable and recalcitrant organic matter were affected by their physical protection within the soil. During cultivation, this physical protection may influence soil carbon levels more than the original decomposition rates of the plant residues (Van Veen and Paul, 1981).

The rate of decomposition of plant residues has been shown to be independent of the amounts of residues added to the soil. Rather, it is the proteins, cellulose, hemicellulose, and lignin constituents of the residues that influence the decomposition rate and the quality and stability of the organic matter produced (Van Veen and Paul, 1981). Soil organic matter equilibrium levels have been shown to be more dependent on the amount and decomposition rates of resistant humic materials present than on decomposition rates of the added residues.

Research has been conducted on the effect of residue quality on soil organic matter formation. (Paustian et al., 1992; Sowden and Atkinson, 1968; Larson et al., 1972). In two experiments, identical amounts of different residues were added to field plots with similar cropping regimes. The highest soil carbon values were found in manure and sawdust-amended plots, having lignin contents of approximately 30%. The next highest was found with the application of wheat straw containing 15% lignin. The lowest carbon values were found where grass litter containing approximately 6% lignin was added (Paustian et al., 1992). Similarly, results from a Canadian study conducted by Sowden and Atkinson (1968), showed highest gains of soil carbon in soils with additions of peat and manure, and the lowest with additions of alfalfa. However, in an eleven year study conducted by Larson et al. (1972), no significant effects of residue type on soil carbon accumulation were found.

Soil organic matter decomposition is also affected by the presence of roots (Balesdent and Balabane, 1996; Kuikman et al., 1991; Helal and Sauerbeck, 1984). The annual input of carbon by roots of growing plants is estimated to be between approximately 0.9 and 3 tC/ha for both arable soils and forests (Kuikman et al., 1991).

The quantity and the quality of the material released from roots into the soil depend on factors such as temperature, soil moisture, and soil nutrients. The carbon which is derived from the roots is transformed by microbial organisms for energy production and growth. A large proportion of this material decomposes easily. The rhizosphere, which is the portion of the soil closest to the plant roots, has the highest microbial activity in the soil. The breakdown of this

root-derived material by microbial organisms is also controlled by other factors such as nutrient status, texture, structure, moisture and temperature (Kuikman et al., 1991). In several studies conducted by Helal and Sauerbeck (1984), living roots were found to enhance the decomposition of soil organic matter. Similarly, in a study by Cheng and Coleman (1990), the presence of plants also led to increased decomposition due to higher microbial biomass than in the unplanted treatments. Helal and Sauerbeck in 1986 and 1987 also showed a higher microbial biomass and a higher soil organic matter decomposition in the rooted zone of soils compared to the root-free zones (Cheng and Coleman, 1990). Another study by Bottner et al. (1988) demonstrated that microbial activity was also increased by the presence of plants, and that the presence of successive living root systems decreased biomass carbon compared to bare soils. These studies therefore suggest that living roots stimulate microbial growth and activity, thereby increasing soil organic matter decomposition. In contrast, a 2 year study performed by Sallih and Bottner (1988), demonstrated the opposite effect of plants on the decomposition of organic matter early in their experiment. From these contradictory studies, it can be concluded that the response of microbial activity to root location is what determines the effect of roots on soil organic matter decomposition. As stated by Cheng and Coleman (1990), if the presence of roots stimulates microbial growth, it will stimulate the loss of soil organic matter. If the presence of roots reduces microbial growth, it will also reduce the loss of soil organic matter.

Recent research has demonstrated that the amount of carbon used for microbial growth decreases with increasing carbon to nitrogen (C:N) and carbon to phosphorus (C:P) ratios (Enriquez et al., 1993). Generally, differences in decomposition rates are related to nutrient content especially when comparing litters from different plant types, and to carbon quality when comparing litter derived from similar plant types (Taylor et al, 1989; Enriquez et al. 1993). Fast-growing plants tend to have high nutrient concentrations, making them good substrates for microbial growth, and therefore subjecting them to rapid decomposition. (Enriquez et al., 1993; Chapin et al., 1987). These studies emphasize the importance of the nutrient content (C:N:P) of plant detritus in regulating decomposition rates.

In general, lignin to nitrogen ratios are much higher in root material compared to aboveground plant material. Since root products are introduced directly into the soil clay matrix, this allows them to be physically protected from microbial attack (Oades, 1995). This can lead to large

accumulations of root-derived products in the soil due to a slower decay of root carbon compared to aboveground carbon (Balesdent and Balabane, 1996).

A2.1.3 Land Use

Agricultural ecosystems, which make up approximately 11% of the earth's terrestrial surface, are highly influenced by land management practices (Houghton et al., 1983; Paustian et al., 1995). As a result, these systems play a significant role in carbon cycling. In eastern Canada, agricultural soils can be considered as having a relatively high potential for carbon and nitrogen storage. Surveys have indicated that soil carbon storage to a depth of 1 meter for agricultural soils range from 30 to 160 tC/ha. This large difference suggests that agricultural land use practices play a major role in influencing soil organic matter storage (Carter et al., 1997).

Agricultural crops can act either as sinks or sources for atmospheric CO₂. The carbon balance in agroecosystems can be reduced to the difference between CO₂ released from burning fossil fuels for farming activities and to the change in soil organic carbon (Smith et al., 1997). According to a study conducted by Smith et al. (1997), the overall rate of carbon loss from agricultural soils in Canada for 1990 was estimated to be 39.1 kg/ha, implying a net loss of 1.9 Mt of carbon, or 7.1 Mt of CO₂. This loss represents 69% of the annual amount of CO₂ released by the burning of fossil fuels used on farms in Canada (10.4 Mt CO₂). Interestingly, rates of soil organic carbon losses for agricultural soils in Canada have been shown to be smaller in 1990 compared to the early 1980s (Smith et al., 1997). This is partly due to the influence of no-till practices introduced to some areas of Canada in the mid 1980s, as well as to a reduction in summerfallow. The highest carbon losses have been observed in the Prairie soils with about 90% of all carbon losses in Canada, mainly because 80% of the agricultural land in Canada is in the Prairies and because most of this land has a high soil organic carbon content. Agricultural lands in Québec have shown a more rapid carbon loss than those in Ontario. Québec agricultural soils (top 30 cm) have an average of 60% higher carbon content than Ontario soils, largely because more hay is grown in Quebec, and because of poorer drainage in Quebec soils due to no subsurface drainage until only recently (15 to 30 years ago). There is also a difference in the soil parent material, with more fine-textured soils being located in Quebec (Smith et al., 1997).

Changes in land-use from 1850 to 1990 have resulted in cumulative CO₂ emissions of approximately 120 GtC, accounting for half of the worldwide CO₂ increase (Houghton, 1995 in

Smith et al., 1997). It has become evident that small changes in terrestrial carbon can have a large impact on atmospheric carbon (Carter et al., 1997).

The conversion of relatively undisturbed ecosystems such as forests and grasslands into intensively managed agroecosystems, has had major global implications on carbon cycling, largely as a result of land clearing, cultivation, and the replacement of perennial vegetation by annual crops (Cole et al., 1993). With land use changes such as forest clearing, carbon is released to the atmosphere immediately (by burning), or more slowly (by decomposition). Once forests are cleared, ground vegetation will usually take over, leading to less efficient carbon storage compared to the original ecosystem (Emanuel et al., 1984). With forest clearing, some carbon released from the tree components is transferred to the atmosphere (by burning or rapid decomposition) while some is transferred to the soil to the detritus/decomposers. The remaining carbon released is transferred out of the system, presumably to a long term residence pool (Emanuel et al., 1984).

Carbon content is typically higher for grassland soils than for forest soils (Stevenson, 1986). Since there are larger quantities of fine roots, etc. under grass soils, there is also a greater production of organic matter. Preservation of nitrogen, and therefore carbon, also occurs in grassland soils because nitrification is inhibited. In addition, the rhizosphere where organic matter is synthesized, is much larger under grass systems than under forest. As well, there is less aeration under grass, leading to organic matter preservation. Grassland soils also have a high base status which promotes NH_3 fixation by lignin, once more leading to the conservation of nitrogen and carbon (Stevenson, 1986).

Studies comparing forested with adjacent cultivated soils, in eastern Canada, have indicated that some agricultural management practices (e.g. grassland) can maintain or increase soil organic matter levels, relative to the forest soil (Gregorich et al., 1995). Therefore, agricultural soil management, and consequently organic carbon inputs, will influence soil carbon storage. However, although land use and improved management may enhance soil C storage, the addition of nutrient supplements and other inputs to the soil, such as lime, may also involve a carbon cost in terms of production, distribution, and application (Carter et al., 1997).

As mentioned previously, soil disrupted mechanically such as with tillage implements, can lead to a decrease in aggregate stability, and therefore result in increased decomposition of

physically protected soil organic matter. This degradation of soil structure and loss of physical protection is known to be a major cause of soil carbon loss when undisturbed soils are cultivated (Paustian et al., 1995; Cambardella and Elliott, 1992). Tillage also influences soil moisture, temperature, aeration, and therefore decomposition rates (Paustian et al., 1995). Hence, the use of reduced and no-till cultivation may influence the decrease organic matter decomposition in agricultural soils (Paustian et al., 1995).

Such deleterious changes in soil organic matter levels following land use changes highlight the need to improve current management strategies within agricultural systems.

A2.1.4 Management Practices for Increasing Soil Organic Carbon Levels

The assimilation of CO₂ through photosynthesis and the release of CO₂ to the atmosphere through plant and heterotroph respiration ultimately determines the carbon balance of terrestrial ecosystems (Paustian et al., 1995). Simply stated, a soil carbon change is the difference between carbon additions to soil and carbon mineralization from soil organic matter. Thus, carbon storage can be increased by increasing carbon inputs, decreasing decomposition rates, and by reducing the amount of CO₂ produced when organic matter is decomposed. Soil management (Paustian et al., 1995) can influence all these processes.

As previously mentioned, grassland soils typically exceed all other well-aerated soils in organic matter content (Stevenson, 1986). In addition, deep-rooted grasses have been found to sequester significant amounts of organic carbon deep in the soil. Research on South American savannas have shown that introduced deep rooted grass-based pastures were able to store organic carbon in soils much more efficiently than the native savanna (Fisher et al., 1994). These pastures were able to sequester most of the carbon in the deeper part of the soil profile, well below the plough layer, making it less prone to oxidation during cropping activities. These perennial systems can therefore accompany rotations with annual crops and still contribute to carbon sequestration. Such deep-rooted grasses may therefore play a vital role in the balance of the global carbon cycle and minimize the greenhouse effect of atmospheric CO₂ (Fisher et al., 1994). Reduced and no-till cultivation has been shown to help decrease organic matter decomposition in agricultural soils (Paustian et al, 1995). For instance, no-till can lead to a reduction in soil temperature, which would lead to a decrease in decomposition, and therefore an accumulation of organic matter. In some instances, however, no-till may actually lead to a

decline in soil organic matter by increasing soil water holding capacity, thus leading to greater decomposition rates (Paustian et al., 1995).

Several studies have demonstrated that changes in soil organic matter levels of various agroecosystems are positively correlated to annual inputs of carbon to the soil (Bolinder and Angers, 1997). Therefore, in order to predict soil organic matter changes, a knowledge of these annual carbon inputs is crucial. However, it is often difficult to estimate annual carbon inputs, particularly those of the root biomass (Bolinder and Angers, 1997). Consequently, the aboveground biomass to root biomass ratio is an essential parameter for estimating total carbon production from aboveground plant biomass. This ratio has been measured to be approximately 5 for corn, and 1 for perennial forage crops. The observed ratio for perennial crops may provide an explanation for the positive effects on soil carbon sequestration. Studies using ^{13}C on corn have shown the proportion of corn residue (stalk and leaves) converted to soil organic matter is 12%, compared with 20% for both cereal (straw), and perennial forage crops (Bolinder and Angers, 1997). Therefore, due to the smaller ratio of aboveground to root biomass ratio, and the greater percentage of residues converted to soil organic matter, perennial forage crops may have a positive effect on the quantity and quality of organic matter returned to the soil, compared to corn crops.

Generally, crops dedicated to forage production will only sequester soil carbon if production processes allowed plant residues to be returned to the soil. Practices which retain or apply organic residues will favor the maintenance of soil organic matter (Bolinder and Angers, 1997). The amount of annual carbon input necessary to maintain soil organic matter in equilibrium depends on the soil texture, climate and initial soil organic matter level. For soils with average soil organic matter levels, several studies indicate that an annual input of approximately 1.75-2.25 tC/ha is sufficient to maintain soil organic matter at an equilibrium (Paustian et al. 1995; Bolinder et Angers, 1997).

In a study conducted at a site in Eastern Canada with perennial grasses, Bolinder and Angers (1997) demonstrated that over a period of 3 years, total soil carbon at 0 to 30 cm increased by 8 tC/ha. All perennial forage crops studied had a positive effect on total soil carbon with an average increase of 8 tC/ha. In addition, there was an increase in microbial biomass and soluble sugars, both indicators of the quality of soil organic matter. As well, there was a positive effect on soil structural stability.

A2.1.5 Biomass Crops as a Means of Carbon Sequestration

Numerous studies have demonstrated the ability of relatively fast-growing plant species to sequester substantial amounts of carbon (e.g. Kürsten and Burschel, 1993; Scurlock et al., 1993; Wright and Hughes, 1993; Hagenstein, 1996). Scurlock et al. (1993) predicted that the conversion of 15-20 million hectares of agricultural land to the growth of biomass crops, represented a potential annual sink of approximately 90-120 million tones of carbon.

Equally important is that biomass crops are being targeted as one of the key renewable energy resources of the future, since they can be used as direct substitutes for fossil fuels, thereby offsetting carbon emissions (Scurlock et al., 1993). Presently, of the major solutions to reducing atmospheric carbon dioxide levels that have been proposed, the sequestering of carbon and the displacing of fossil fuels through the use of biomass produced from relatively fast-growing plant species is considered among the more promising (Rubin et al., 1992).

The growing of perennial crops such as switchgrass (*Panicum virgatum* L.) and short-rotation forestry willow (*Salix* sp.) for biomass energy production, provides an excellent opportunity for CO₂ mitigation through the displacement of fossil fuels and increased soil carbon storage, in the form of above- and/or belowground biomass.

Appendix 3

Additional Tables for Chapter 4

Table A3.1: Base Case Values for Cropping Systems			
	Yield (odt/ha)	Land Rent (\$/ha)	Annual Increment in Soil C (kg C/ha)
SRF Willow	9	125	500
Switchgrass – Spring	8	125	500
Switchgrass – Fall	10.5	125	500

Table A3.2: Energy Budget Breakdown for Cropping Systems*		
SRF Willow		
	GJ/ha	%
Tillage/Planting/Cuttings	2.22	2
Fertilization	63.78	57
Weed Control	3.24	3
Harvest/Transport	<u>41.86</u>	<u>38</u>
Total over 20 years	111.10	100
Switchgrass – Spring		
Establishment	2.07	3
Fertilization	33.14	51
Harvest/Transport	<u>30.29</u>	<u>46</u>
Total over 10 years	65.50	100
Switchgrass – Fall		
Establishment	2.07	3
Fertilization	40.04	52
Harvest/Transport	<u>34.25</u>	<u>45</u>
Total over 10 years	76.36	100
Switchgrass – Mean		
Establishment	2.07	3
Fertilization	36.59	51.5
Harvest/Transport	<u>32.27</u>	<u>45.5</u>
Total over 10 years	70.93	100

* Base Case Scenarios.

Table A3.3: Carbon Budget Breakdown for Cropping Systems*		
SRF Willow		
	Kg C/ha	%
Tillage/Planting/Cuttings	42.6	2
Fertilization	1154.7	55
Weed Control	77.3	4
Harvest/Transport	<u>807.1</u>	<u>39</u>
Total over 20 years	2081.7	100
Switchgrass – Spring		
Establishment	40.3	3
Fertilization	567.3	48
Harvest/Transport	<u>584.0</u>	<u>49</u>
Total over 10 years	1191.6	100
Switchgrass – Fall		
Establishment	40.4	3
Fertilization	715.7	50
Harvest/Transport	<u>660.4</u>	<u>47</u>
Total over 10 years	1416.5	100
Switchgrass – Mean		
Establishment	40.35	3
Fertilization	641.50	49
Harvest/Transport	<u>622.20</u>	<u>48</u>
Total over 10 years	1304.05	100

* Base Case Scenarios

Table A3.4: Estimated Use of Fossil Fuel Energy and Carbon Emitted over the Life Span of SRF Willow Plantation*		
Category	Fossil Fuel Energy Used over 20 Years GJ/ha	Carbon Emitted as Fossil Fuel Over 20 Years kg C/ha
Cuttings	0.21	3.72
Herbicide	2.26	58.52
Fertilizers	63.47	1,148.75
Plowing	0.79	15.27
Discing	0.00	0.00
Harrowing	0.69	13.38
Planting	0.53	10.21
Rotary Hoeing	0.20	3.77
Cultivation	0.37	7.20
Spraying	0.40	7.80
Fertilizer Application	0.31	6.00
Harvesting	14.49	279.45
On-Farm Transport	0.49	9.43
Off-Farm Transport	26.88	518.24
Total	111.10	2,081.74
Annual Average	5.50	104.09

* Base Case Scenarios.

Table A3.5: Estimated Use of Fossil Fuel Energy and Carbon Emitted over the Life Span of Switchgrass – Spring*		
Category	Fossil Fuel Energy Used over 10 Years GJ/ha	Carbon Emitted as Fossil Fuel over 10 Years kg C/ha
Seed	0.43	8.78
Herbicide	0.00	0.00
Fertilizers	32.58	556.47
Plowing	0.79	15.27
Discing	0.00	0.00
Harrowing	0.69	13.38
Planting	0.15	2.92
Spraying	0.00	0.00
Fertilizer Application	0.56	10.81
Mowing	2.49	48.03
Baling	14.13	272.51
On-Farm Transport	0.98	18.87
Off-Farm Transport	12.69	244.59
Total	65.50	1,182.83
Annual Average	6.55	118.28

* Base Case Scenarios.

Table A3.6: Estimated Use of Fossil Fuel Energy and Carbon Emitted over the Life Span of Switchgrass – Fall*		
Category	Fossil Fuel Energy Used over 10 Years GJ/ha	Carbon Emitted as Fossil Fuel over 10 Years kg C/ha
Seed	0.43	8.78
Herbicide	0.00	0.00
Fertilizers	39.48	704.94
Plowing	0.79	15.27
Discing	0.00	0.00
Harrowing	0.69	13.38
Planting	0.15	2.92
Spraying	0.00	0.00
Fertilizer Application	0.56	10.81
Mowing	2.49	48.03
Baling	14.13	272.51
On-Farm Transport	0.98	18.87
Off-Farm Transport	16.65	321.02
Total	76.36	1,416.51
Annual Average	7.64	141.65

* Base Case Scenarios.

Appendix 4

Model Simulation Results for SRF Willow

Table A4.1: Summary of SRF Willow Results

Table 1: Economics			
Cost/odMg:	Full-Cost		68.39
	Variable Cost		22.65
	Labour		5.16
	V.C.+ Labour		27.80
	V.C.+ Off Farm Trans.		33.74
	V.C.+ Rent		37.92
	V.C.+ Off Farm Trans. + Rent		49.01
	Fixed Cost		12.38
Table 2: Inputs			
	T-Bill Rate		0.0486
	Discount Rate		0.05
	Max Yield	odt/ha	9
	Land Rent	\$/ha	125
	Land Clearing	\$/ha	500
Table 3: Energy Budget			
Energy Ratio:	Total Harvestable Energy (GJ)		3,299.40
	Total Energy Used (GJ)		111.10
	Ratio		29.70
Table 4: Carbon Requirements			
Straight Ratio:			
	Fossil Carbon Required:	kg C/ha	2,081.74
	Biomass Energy Produced:	GJ/ha	3,299.40
	Carbon Requirement:	kg C/GJ	0.63
Ratio Adjusted for Soil Carbon Accumulation:			
	Annual Increment in Soil Carbon:	kg C/ha/yr	500
	Net Carbon Required	Kg C/ha	-7,918
	Carbon Requirement:	kg C/GJ	-2.40
Ratio Adjusted for Soil Carbon Accumulation and Changes in Landscape:			
	Net Carbon Required	kg C/ha	-19,149
	Carbon Requirement:	kg C/GJ	-5.80
ABOVE GROUND CARBON			
	Corn	kg C/ha	7166
	Willow	kg C/ha	15314
	Difference	kg C/ha	8148
BELOW GROUND CARBON			
	Corn	kg C/ha	660
	Willow	kg C/ha	3743
	Difference	kg C/ha	3083

Table A4.3: Energy Budget for SRF Willows

Activity/Year	1	2	3	4	5	6	7	8	9	10	11	12	13	14	15	16	17	18	19	20	TOTAL	
Cullings	0.21	0.00	0.00	0.00	0.00	0.00	0.00	0.00	0.00	0.00	0.00	0.00	0.00	0.00	0.00	0.00	0.00	0.00	0.00	0.00	0.00	0.21
Herbicide	1.03	0.00	0.00	0.00	0.31	0.00	0.00	0.00	0.31	0.00	0.00	0.00	0.31	0.00	0.00	0.00	0.31	0.00	0.00	0.00	0.00	2.26
Fertilizers	0.00	12.13	0.00	0.00	12.83	0.00	0.00	0.00	12.84	0.00	0.00	0.00	12.84	0.00	0.00	0.00	12.84	0.00	0.00	0.00	0.00	63.47
Planting	0.79	0.00	0.00	0.00	0.00	0.00	0.00	0.00	0.00	0.00	0.00	0.00	0.00	0.00	0.00	0.00	0.00	0.00	0.00	0.00	0.00	0.79
Discing	0.00	0.00	0.00	0.00	0.00	0.00	0.00	0.00	0.00	0.00	0.00	0.00	0.00	0.00	0.00	0.00	0.00	0.00	0.00	0.00	0.00	0.00
Harrowing	0.69	0.00	0.00	0.00	0.00	0.00	0.00	0.00	0.00	0.00	0.00	0.00	0.00	0.00	0.00	0.00	0.00	0.00	0.00	0.00	0.00	0.69
Planting	0.53	0.00	0.00	0.00	0.00	0.00	0.00	0.00	0.00	0.00	0.00	0.00	0.00	0.00	0.00	0.00	0.00	0.00	0.00	0.00	0.00	0.53
Rotary Hoing	0.20	0.00	0.00	0.00	0.00	0.00	0.00	0.00	0.00	0.00	0.00	0.00	0.00	0.00	0.00	0.00	0.00	0.00	0.00	0.00	0.00	0.20
Cultivation	0.37	0.00	0.00	0.00	0.00	0.00	0.00	0.00	0.00	0.00	0.00	0.00	0.00	0.00	0.00	0.00	0.00	0.00	0.00	0.00	0.00	0.37
Spraying	0.17	0.00	0.00	0.00	0.06	0.00	0.00	0.00	0.06	0.00	0.00	0.00	0.06	0.00	0.00	0.00	0.06	0.00	0.00	0.00	0.00	0.40
Fertilizer Application	0.00	0.06	0.00	0.00	0.06	0.00	0.00	0.00	0.06	0.00	0.00	0.00	0.06	0.00	0.00	0.00	0.06	0.00	0.00	0.00	0.00	0.31
Harvesting	0.00	0.00	0.00	2.90	0.00	0.00	0.00	2.90	0.00	0.00	0.00	2.90	0.00	0.00	0.00	2.90	0.00	0.00	0.00	0.00	0.00	14.49
On-Farm Transport	0.00	0.00	0.00	0.10	0.00	0.00	0.00	0.10	0.00	0.00	0.00	0.10	0.00	0.00	0.00	0.10	0.00	0.00	0.00	0.00	0.00	0.49
TOTAL	3.99	12.20	0.00	3.00	13.26	0.00	0.00	3.00	13.27	0.00	0.00	3.00	13.27	0.00	0.00	3.00	13.27	0.00	0.00	0.00	0.00	3.00
TOTAL OVER 20 YEARS:	84.22																					
AVERAGE:	4.21																					
Off-farm Transport (custom)	GJ/ha	0.00	0.00	0.00	0.00	0.00	0.00	0.00	0.00	0.00	0.00	0.00	0.00	0.00	0.00	0.00	0.00	0.00	0.00	0.00	0.00	26.88
TOTAL OVER 20 YEARS:	26.88																					
AVERAGE:	1.34																					
NOTE: assumes average annual yield from economics worksheet times 4 for a 4 year cycle. Limitation: does not capture lower for the first cycle																						
GRAND TOTAL	GJ/ha	3.99	12.20	0.00	7.00	13.26	0.00	0.00	8.72	13.27	0.00	8.72	13.27	0.00	0.00	8.72	13.27	0.00	0.00	0.00	8.72	
TOTAL OVER 20 YEARS:	111.10																					
AVERAGE:	5.56																					
ENERGY RATIO:																						
TOTAL HARVESTABLE ENERGY	GJ/ha	3.299.40																				
TOTAL ENERGY USED	GJ/ha	111.10																				
RATIO		30																				

Table A4.4: Carbon Budget for SRF Willows
Carbon Budget for SRF Willows

Activity/Year	1	2	3	4	5	6	7	8	9	10	11	12	13	14	15	16	17	18	19	20	TOTAL		
Variable Costs:																							
Chipping	3.72	0.00	0.00	0.00	0.00	0.00	0.00	0.00	0.00	0.00	0.00	0.00	0.00	0.00	0.00	0.00	0.00	0.00	0.00	0.00	0.00	3.72	
Herbicides	28.51	0.00	0.00	0.00	8.00	0.00	0.00	0.00	8.00	0.00	0.00	0.00	8.00	0.00	0.00	0.00	8.00	0.00	0.00	0.00	0.00	0.00	58.52
Fertilizers	0.00	208.21	0.00	0.00	234.90	0.00	0.00	0.00	235.21	0.00	0.00	0.00	235.21	0.00	0.00	0.00	235.21	0.00	0.00	0.00	0.00	0.00	1,148.75
Planting	15.27	0.00	0.00	0.00	0.00	0.00	0.00	0.00	0.00	0.00	0.00	0.00	0.00	0.00	0.00	0.00	0.00	0.00	0.00	0.00	0.00	0.00	15.27
Discing	0.00	0.00	0.00	0.00	0.00	0.00	0.00	0.00	0.00	0.00	0.00	0.00	0.00	0.00	0.00	0.00	0.00	0.00	0.00	0.00	0.00	0.00	0.00
Harrowing	0.00	0.00	0.00	0.00	0.00	0.00	0.00	0.00	0.00	0.00	0.00	0.00	0.00	0.00	0.00	0.00	0.00	0.00	0.00	0.00	0.00	0.00	0.00
Planting	13.38	0.00	0.00	0.00	0.00	0.00	0.00	0.00	0.00	0.00	0.00	0.00	0.00	0.00	0.00	0.00	0.00	0.00	0.00	0.00	0.00	0.00	13.38
Rotary Hoeing	10.21	0.00	0.00	0.00	0.00	0.00	0.00	0.00	0.00	0.00	0.00	0.00	0.00	0.00	0.00	0.00	0.00	0.00	0.00	0.00	0.00	0.00	10.21
Cultivation	3.77	0.00	0.00	0.00	0.00	0.00	0.00	0.00	0.00	0.00	0.00	0.00	0.00	0.00	0.00	0.00	0.00	0.00	0.00	0.00	0.00	0.00	3.77
Spraying	7.20	0.00	0.00	0.00	0.00	0.00	0.00	0.00	0.00	0.00	0.00	0.00	0.00	0.00	0.00	0.00	0.00	0.00	0.00	0.00	0.00	0.00	7.20
Fertilizer Application	3.34	0.00	0.00	0.00	1.11	0.00	0.00	0.00	1.11	0.00	0.00	0.00	1.11	0.00	0.00	0.00	1.11	0.00	0.00	0.00	0.00	0.00	6.00
Harvesting	0.00	0.00	0.00	0.00	1.20	0.00	0.00	0.00	1.20	0.00	0.00	0.00	1.20	0.00	0.00	0.00	1.20	0.00	0.00	0.00	0.00	0.00	6.00
On-Farm Transport	0.00	0.00	0.00	55.89	0.00	0.00	0.00	55.89	0.00	0.00	0.00	55.89	0.00	0.00	0.00	55.89	0.00	0.00	0.00	0.00	0.00	0.00	279.45
	0.00	0.00	0.00	1.89	0.00	0.00	0.00	1.89	0.00	0.00	0.00	1.89	0.00	0.00	0.00	1.89	0.00	0.00	0.00	0.00	0.00	0.00	9.43
TOTAL	83.40	209.41	0.00	57.78	245.22	0.00	0.00	57.78	245.53	0.00	0.00	57.78	245.53	0.00	0.00	57.78	245.53	0.00	0.00	0.00	0.00	57.78	57.78
TOTAL OVER 20 YEARS:	1,563.49																						
AVERAGE:	78.17																						
Off-farm Transport (custom)	0.00	0.00	0.00	77.19	0.00	0.00	0.00	110.26	0.00	0.00	0.00	110.26	0.00	0.00	0.00	110.26	0.00	0.00	0.00	0.00	0.00	0.00	518.24
TOTAL OVER 20 YEARS:	518.24																						
AVERAGE:	25.91																						
NOTES: emissions from oil and equipment manufacture not included																							
GRAND TOTAL	83.40	209.41	0.00	134.96	245.22	0.00	0.00	168.04	245.53	0.00	0.00	168.04	245.53	0.00	0.00	168.04	245.53	0.00	0.00	0.00	0.00	168.04	168.04
TOTAL OVER 20 YEARS:	2081.74																						
AVERAGE:	104.09																						
Carbon Requirement:																							

NOTES: emissions from oil and equipment manufacture not included

NOTES: emissions from oil and equipment manufacture not included

Carbon Requirement: 0.63

Table A4.5: Simulation Results for SRF Willows

* Base Case Values

Table 1: Economics		Land Rent = 125 Annual Inc. in C = 500		Yield=9 Ann.Inc in C=500		175		Yield=9 Land Rent=125		1000				
		Yield=7	8	9 +	10	11	Rent=75	100	125	150	Inc.=260	500	750	1000
Cost/odMg:	Full-Cost	84.77	75.56	68.40	62.67	57.98	62.29	65.35	68.40	71.46	74.51	68.40	68.40	68.40
	Variable Cost	29.13	25.49	22.65	20.39	18.54	22.65	22.65	22.65	22.65	22.65	22.65	22.65	22.65
	Labour	6.63	5.80	5.16	4.64	4.22	5.16	5.16	5.16	5.16	5.16	5.16	5.16	5.16
	V.C.+ Labour	35.75	31.29	27.81	25.03	22.75	27.81	27.81	27.81	27.81	27.81	27.81	27.81	27.81
	V.C.+ Off Farm Trans.	40.22	36.58	33.75	31.49	29.63	33.75	33.75	33.75	33.75	33.75	33.75	33.75	33.75
	V.C.+ Rent	48.76	42.66	37.92	34.13	31.03	31.82	34.87	37.92	40.98	44.03	37.92	37.92	37.92
	V.C.+ Off Farm Trans. + Rent	59.86	53.76	49.02	45.23	42.13	42.91	45.97	49.02	52.08	55.13	49.02	49.02	49.02
	Fixed Cost	15.91	13.93	12.38	11.14	10.13	12.38	12.38	12.38	12.38	12.38	12.38	12.38	12.38
Table 2: Inputs														
T-Bill Rate		0.0486												
Discount Rate		0.05												
Max Yield		9												
Land Rent		125												
Land Clearing		500												
Table 3: Energy Budget														
Energy Ratio:														
Total Harvestable Energy (GJ)		2,566.20												
Total Energy Used (GJ)		105.13												
Ratio		24.41												
Table 4: Carbon Requirements														
Fossil Carbon Required:		1,966.57												
Biomass Energy Produced:		2,566.20												
Carbon Requirement:		0.77												
Annual Increment in Soil Carbon:		500												
Net Carbon Required		-8.033												
Carbon Requirement:		-3.13												
Net Carbon Required		-19.264												
Carbon Requirement:		-7.51												
ABOVE GROUND CARBON														
Corn		7166												
Willow		15314												
Difference		8148												
BELOW GROUND CARBON														
Corn		660												
Willow		3743												
Difference		3083												

Appendix 5

Model Simulation Results for Switchgrass - Spring

Table A5.1: Summary of Switchgrass – Spring Results

Table 1: Economics			
Cost/odMg:	Full-Cost		54.67
	Variable Cost		14.59
	Labour		2.91
	V.C.+ Labour		17.50
	V.C.+ Off Farm Trans.		27.27
	V.C.+ Rent		32.02
	V.C.+ Off Farm Trans. + Rent		44.71
	Fixed Cost		7.06
Table 2: Inputs			
	T-Bill Rate		0.0486
	Discount Rate		0.05
	Max Yield	odt/ha	8
	Land Rent	\$/ha	125
Table 3: Energy Budget			
Energy Ratio:	Total Harvestable Energy	(GJ)	1,281.40
	Total Energy Used	(GJ)	66.39
	Ratio		19.29
Table 4: Carbon Requirements			
Straight Ratio:			
	Fossil Carbon Required:	kg C/ha	1,213.96
	Biomass Energy Produced:	GJ/ha	1,281.00
	Carbon Requirement:	kg C/GJ	0.95
Ratio Adjusted for Soil Carbon Accumulation:			
	Annual Increment in Soil Carbon:	kg C/ha/yr	500
	Net Carbon Required	Kg C/ha	-3,786
	Carbon Requirement:	kg C/GJ	-2.96
Ratio Adjusted for Soil Carbon Accumulation and Changes in Landscape:			
	Net Carbon Required	kg C/ha	-6,083
	Carbon Requirement:	kg C/GJ	-4.75
ABOVE GROUND CARBON			
	Corn	kg C/ha	7166
	Switchgrass	kg C/ha	6974
	Difference	kg C/ha	-192
BELOW GROUND CARBON			
	Corn	kg C/ha	660
	Switchgrass	kg C/ha	3149
	Difference	kg C/ha	2489

Table A5.2: Economic Budget for Switchgrass - Spring

Activity/Year	1	2	3	4	5	6	7	8	9	10	TOTAL
Variable Costs											
Seed	\$/ha	70.00	0.00	0.00	0.00	0.00	0.00	0.00	0.00	0.00	70.00
Herbicide	\$/ha	56.38	0.00	0.00	0.00	0.00	0.00	0.00	0.00	0.00	0.00
Fertilizers	\$/ha	0.00	51.00	51.00	51.00	51.00	51.00	51.00	51.00	51.00	459.00
Planting	\$/ha	17.22	0.00	0.00	0.00	0.00	0.00	0.00	0.00	0.00	17.22
Discing	\$/ha	0.00	0.00	0.00	0.00	0.00	0.00	0.00	0.00	0.00	0.00
Harrowing	\$/ha	8.66	0.00	0.00	0.00	0.00	0.00	0.00	0.00	0.00	8.66
Spraying	\$/ha	5.85	0.00	0.00	0.00	0.00	0.00	0.00	0.00	0.00	5.85
Fertilizer Application	\$/ha	6.82	0.00	0.00	0.00	0.00	0.00	0.00	0.00	0.00	0.00
Mowing	\$/ha	0.00	2.91	2.91	2.91	2.91	2.91	2.91	2.91	2.91	26.19
Baling	\$/ha	19.37	19.37	19.37	19.37	19.37	19.37	19.37	19.37	19.37	193.70
Twine	\$/ha	2.80	6.40	8.00	8.00	8.00	8.00	8.00	8.00	8.00	73.20
On-Farm Transport	\$/ha	2.25	2.25	2.25	2.25	2.25	2.25	2.25	2.25	2.25	22.45
Operating Interest	\$/ha	4.69	2.11	2.14	2.14	2.14	2.14	2.14	2.14	2.14	23.95
TOTAL		199.82	89.82	91.46	91.46	91.46	91.46	91.46	91.46	91.46	914.6
Discounted PV		190.30	81.47	79.01	75.24	66.25	65.00	61.90	58.95	56.15	
		807.94									
Labour											
Plowing	\$/ha	8.48	0.00	0.00	0.00	0.00	0.00	0.00	0.00	0.00	8.48
Discing	\$/ha	0.00	0.00	0.00	0.00	0.00	0.00	0.00	0.00	0.00	0.00
Harrowing	\$/ha	5.25	0.00	0.00	0.00	0.00	0.00	0.00	0.00	0.00	5.25
Planting	\$/ha	5.36	0.00	0.00	0.00	0.00	0.00	0.00	0.00	0.00	5.36
Spraying	\$/ha	4.57	0.00	0.00	0.00	0.00	0.00	0.00	0.00	0.00	0.00
Fertilizer Application	\$/ha	0.00	3.03	3.03	3.03	3.03	3.03	3.03	3.03	3.03	32.83
Mowing	\$/ha	3.28	3.28	3.28	3.28	3.28	3.28	3.28	3.28	3.28	32.83
Baling	\$/ha	6.00	6.00	6.00	6.00	6.00	6.00	6.00	6.00	6.00	60.00
On-Farm Transport	\$/ha	6.00	6.00	6.00	6.00	6.00	6.00	6.00	6.00	6.00	60.00
TOTAL		38.94	18.31	18.31	18.31	18.31	18.31	18.31	18.31	18.31	203.76
Discounted PV		37.08	16.61	15.82	15.07	13.67	13.02	12.40	11.81	11.24	
		161.05									
Fixed Costs											
Plowing	\$/ha	22.24	0.00	0.00	0.00	0.00	0.00	0.00	0.00	0.00	22.24
Discing	\$/ha	0.00	0.00	0.00	0.00	0.00	0.00	0.00	0.00	0.00	0.00
Harrowing	\$/ha	9.29	0.00	0.00	0.00	0.00	0.00	0.00	0.00	0.00	9.29
Planting	\$/ha	8.49	0.00	0.00	0.00	0.00	0.00	0.00	0.00	0.00	8.49
Spraying	\$/ha	10.53	0.00	0.00	0.00	0.00	0.00	0.00	0.00	0.00	0.00
Fertilizer Application	\$/ha	0.00	4.01	4.01	4.01	4.01	4.01	4.01	4.01	4.01	36.13
Mowing	\$/ha	6.02	6.02	6.02	6.02	6.02	6.02	6.02	6.02	6.02	60.24
Baling	\$/ha	28.12	28.12	28.12	28.12	28.12	28.12	28.12	28.12	28.12	281.22
On-Farm Transport	\$/ha	6.71	6.71	6.71	6.71	6.71	6.71	6.71	6.71	6.71	67.10
TOTAL		91.40	44.87	44.87	44.87	44.87	44.87	44.87	44.87	44.87	448.7
Discounted PV		87.05	40.70	38.76	36.92	33.48	31.89	30.37	28.92	27.55	
		390.80									
Off-farm Transport (custom)	\$/ha	35.51	81.16	101.45	101.45	101.45	101.45	101.45	101.45	101.45	928.31
Land rent	\$/ha	125.00	125.00	125.00	125.00	125.00	125.00	125.00	125.00	125.00	1,250.00
GRAND TOTAL		490.87	359.17	381.10	381.10	381.10	381.10	381.10	381.10	381.10	3,811.0
Discounted Cost	\$/ha	467.30	325.78	329.21	313.53	284.38	270.64	257.94	245.66	233.96	
Total Present Value	\$/ha	\$3,027									
Yield	odMg	2.80	6.40	8.00	8.00	8.00	8.00	8.00	8.00	8.00	8.00
Discounted Yield	odMg	2.67	5.80	6.91	6.58	6.27	5.99	5.41	5.16	4.91	
Total Discounted Yield	odMg	55.37									
COST/ODMg											
Full-Cost											
		54.67									

Table A5.3: Energy Budget for Switchgrass - Spring

Activity/Year	1	2	3	4	5	6	7	8	9	10	TOTAL
Seed	0.43	0.00	0.00	0.00	0.00	0.00	0.00	0.00	0.00	0.00	0.43
Herbicide	0.78	0.00	0.00	0.00	0.00	0.00	0.00	0.00	0.00	0.00	0.78
Fertilizers	0.00	3.62	3.62	3.62	3.62	3.62	3.62	3.62	3.62	3.62	32.58
Plowing	0.79	0.00	0.00	0.00	0.00	0.00	0.00	0.00	0.00	0.00	0.79
Discing	0.00	0.00	0.00	0.00	0.00	0.00	0.00	0.00	0.00	0.00	0.00
Harrowing	0.69	0.00	0.00	0.00	0.00	0.00	0.00	0.00	0.00	0.00	0.69
Planting	0.15	0.00	0.00	0.00	0.00	0.00	0.00	0.00	0.00	0.00	0.15
Spraying	0.12	0.00	0.00	0.00	0.00	0.00	0.00	0.00	0.00	0.00	0.12
Fertilizer Application	0.00	0.06	0.06	0.06	0.06	0.06	0.06	0.06	0.06	0.06	0.56
Mowing	0.25	0.25	0.25	0.25	0.25	0.25	0.25	0.25	0.25	0.25	2.49
Baling	1.41	1.41	1.41	1.41	1.41	1.41	1.41	1.41	1.41	1.41	14.13
On-Farm Transport	0.10	0.10	0.10	0.10	0.10	0.10	0.10	0.10	0.10	0.10	0.98
TOTAL	4.72	5.44	5.44	5.44	5.44	5.44	5.44	5.44	5.44	5.44	5.44
TOTAL OVER 10 YEARS:	53.70										
AVERAGE:	5.37										
Off-farm Transport (custom)	0.49	1.11	1.39	1.39	1.39	1.39	1.39	1.39	1.39	1.39	12.69
TOTAL OVER 10 YEARS:	12.69										
AVERAGE:	1.27										
GRAND TOTAL	5.21	6.55	6.83	6.83	6.83	6.83	6.83	6.83	6.83	6.83	6.83
TOTAL OVER 10 YEARS:	66.39										
AVERAGE:	6.64										
ENERGY RATIO:											
TOTAL HARVESTABLE ENERGY	GJ	1,281.00									
TOTAL ENERGY USED	GJ	66.39									
RATIO		19									

Table A5.4: Carbon Budget for Switchgrass - Spring

Activity/Year	1	2	3	4	5	6	7	8	9	10	TOTAL
Variable Costs:											
Seed	8.78	0.00	0.00	0.00	0.00	0.00	0.00	0.00	0.00	0.00	8.78
Herbicides	20.12	0.00	0.00	0.00	0.00	0.00	0.00	0.00	0.00	0.00	0.00
Fertilizers	0.00	61.83	61.83	61.83	61.83	61.83	61.83	61.83	61.83	61.83	556.47
Plowing	15.27	0.00	0.00	0.00	0.00	0.00	0.00	0.00	0.00	0.00	15.27
Discing	0.00	0.00	0.00	0.00	0.00	0.00	0.00	0.00	0.00	0.00	0.00
Harrowing	13.38	0.00	0.00	0.00	0.00	0.00	0.00	0.00	0.00	0.00	13.38
Planting	2.92	0.00	0.00	0.00	0.00	0.00	0.00	0.00	0.00	0.00	2.92
Spraying	2.23	0.00	0.00	0.00	0.00	0.00	0.00	0.00	0.00	0.00	0.00
Fertilizer Application	0.00	1.20	1.20	1.20	1.20	1.20	1.20	1.20	1.20	1.20	10.81
Mowing	4.80	4.80	4.80	4.80	4.80	4.80	4.80	4.80	4.80	4.80	48.03
Baling	27.25	27.25	27.25	27.25	27.25	27.25	27.25	27.25	27.25	27.25	272.51
On-Farm Transport	1.89	1.89	1.89	1.89	1.89	1.89	1.89	1.89	1.89	1.89	18.87
TOTAL	96.63	96.97	96.97	96.97	96.97	96.97	96.97	96.97	96.97	96.97	96.97
TOTAL OVER 10 YEARS:	969.37										
AVERAGE:	96.94										
NOTES: emissions from equipment manufacture not included											
Off-farm Transport (custom)	9.36	21.38	26.73	26.73	26.73	26.73	26.73	26.73	26.73	26.73	244.59
TOTAL OVER 10 YEARS:	244.59										
AVERAGE:	24.46										
NOTES: emissions from equipment manufacture not included											
GRAND TOTAL	105.99	118.36	123.70	123.70	123.70	123.70	123.70	123.70	123.70	123.70	123.70
TOTAL OVER 10 YEARS:	1,213.96										
AVERAGE:	121.40										

Carbon Requirement: 0.95

Table A5.5: Simulation Results for Switchgrass - Spring

* Base Case Values

	Land Rent = 125 Annual Inc. in C = 500													
	Yield=6	7	8 *	9	10	Rent=75	100	125	150	175	Yield=8 Land Rent=125			
	nn.Inc.=25	500	750	1000	125	150	175	200	225	250	275	300	325	350
Table 1: Economics														
Cost/odMg:	Full-Cost	68.33	60.52	54.67	50.12	46.48	47.70	51.19	54.67	58.16	61.64	54.67	54.67	54.67
	Variable Cost	19.11	16.53	14.59	13.08	11.88	14.59	14.59	14.59	14.59	14.59	14.59	14.59	14.59
	Labour	3.88	3.32	2.91	2.59	2.33	2.91	2.91	2.91	2.91	2.91	2.91	2.91	2.91
	V.C.+ Labour	22.99	19.85	17.50	15.67	14.20	17.50	17.50	17.50	17.50	17.50	17.50	17.50	17.50
	V.C.+ Off Farm Trans.	31.80	29.21	27.27	25.77	24.56	27.27	27.27	27.27	27.27	27.27	27.27	27.27	27.27
	V.C.+ Rent	42.36	36.45	32.02	28.58	25.82	32.02	32.02	32.02	32.02	32.02	32.02	32.02	32.02
	V.C.+ Off Farm Trans. + Rent	55.04	49.13	44.71	41.26	38.51	44.71	44.71	44.71	44.71	44.71	44.71	44.71	44.71
	Fixed Cost	9.41	8.07	7.06	6.27	5.65	7.06	7.06	7.06	7.06	7.06	7.06	7.06	7.06
Table 2: Inputs														
T-Bill rate		0.0486	0.0486	0.0486	0.0486	0.0486	0.0486	0.0486	0.0486	0.0486	0.0486	0.0486	0.0486	0.0486
Discount rate		0.05	0.05	0.05	0.05	0.05	0.05	0.05	0.05	0.05	0.05	0.05	0.05	0.05
Max Yield		6	7	8	9	10	8	8	8	8	8	8	8	8
Land Rent		125	125	125	125	125	75	100	125	150	175	125	125	125
Table 3: Energy Budget														
Energy Ratio:	Total Harvestable Energy (GJ)	960.75	1,120.88	1,281.00	1,441.13	1,601.25	1,281.00	1,281.00	1,281.00	1,281.00	1,281.00	1,281.00	1,281.00	1,281.00
	Total Energy Used (GJ)	63.22	64.80	66.39	67.98	69.56	66.39	66.39	66.39	66.39	66.39	66.39	66.39	66.39
	Ratio	15.20	17.30	19.29	21.20	23.02	19.29	19.29	19.29	19.29	19.29	19.29	19.29	19.29
Table 4: Carbon Requirements														
	Fossil Carbon Required	1,152.81	1,183.39	1,213.96	1,244.53	1,275.11	1,213.96	1,213.96	1,213.96	1,213.96	1,213.96	1,213.96	1,213.96	1,213.96
	Biomass Energy Produced:	960.75	1,120.88	1,281.00	1,441.13	1,601.25	1,281.00	1,281.00	1,281.00	1,281.00	1,281.00	1,281.00	1,281.00	1,281.00
	Carbon Requirement	1.20	1.06	0.95	0.86	0.80	0.95	0.95	0.95	0.95	0.95	0.95	0.95	0.95
	Annual Increment in Soil Carbon	500	500	500	500	500	500	500	500	500	500	500	500	500
	Net Carbon Required	-3847	-3817	-3786	-3755	-3725	-3786	-3786	-3786	-3786	-3786	-3786	-3786	-3786
	Carbon Requirement	-6144	-6114	-6083	-6052	-6022	-6083	-6083	-6083	-6083	-6083	-6083	-6083	-6083
	Net Carbon Required	-4.00	-3.41	-2.96	-2.61	-2.33	-2.96	-2.96	-2.96	-2.96	-2.96	-2.96	-2.96	-2.96
	Carbon Requirement	-6.40	-5.45	-4.75	-4.20	-3.76	-4.75	-4.75	-4.75	-4.75	-4.75	-4.75	-4.75	-4.75
ABOVE GROUND CARBON														
	Corn	7166	7166	7166	7166	7166	7166	7166	7166	7166	7166	7166	7166	7166
	Switchgrass	6974	6974	6974	6974	6974	6974	6974	6974	6974	6974	6974	6974	6974
	Difference	-192	-192	-192	-192	-192	-192	-192	-192	-192	-192	-192	-192	-192
BELOW GROUND CARBON														
	Corn	660	660	660	660	660	660	660	660	660	660	660	660	660
	Switchgrass	3149	3149	3149	3149	3149	3149	3149	3149	3149	3149	3149	3149	3149
	Difference	2489	2489	2489	2489	2489	2489	2489	2489	2489	2489	2489	2489	2489

Appendix 6

Model Simulation Results for Switchgrass - Fall

Table A6.1: Summary of Switchgrass - Fall Results

Table 1: Economics			
Cost/odMg:	Full-Cost		46.92
	Variable Cost		13.36
	Labour		2.22
	V.C.+ Labour		15.58
	V.C.+ Off Farm Trans.		26.05
	V.C.+ Rent		26.65
	V.C.+ Off Farm Trans. + Rent		39.33
	Fixed Cost		5.38
Table 2: Inputs			
	T-Bill Rate		0.0486
	Discount Rate		0.05
	Max Yield	odt/ha	10.5
	Land Rent	\$/ha	125
Table 5: Energy Budget			
Energy Ratio:	Total Harvestable Energy (GJ)		1681.31
	Total Energy Used (GJ)		77.25
	Ratio		21.76
Table 8: Carbon Requirements			
Straight Ratio:			
	Fossil Carbon Required:	kg C/ha	1,438.86
	Biomass Energy Produced:	GJ/ha	1.681.31
	Carbon Requirement:	kg C/GJ	0.86
Ratio Adjusted for Soil Carbon Accumulation:			
	Annual Increment in Soil Carbon:	kg C/ha/yr	500
	Net Carbon Required	Kg C/ha	-3,561
	Carbon Requirement:	kg C/GJ	-2.12
Ratio Adjusted for Soil Carbon Accumulation and Changes in Landscape:			
	Net Carbon Required	kg C/ha	-5,858
	Carbon Requirement:	kg C/GJ	-3.48
ABOVE GROUND CARBON			
	Corn	kg C/ha	7166
	Switchgrass	kg C/ha	6974
	Difference	kg C/ha	-192
BELOW GROUND CARBON			
	Corn	kg C/ha	660
	Switchgrass	kg C/ha	3149
	Difference	kg C/ha	2489

Table A6.2: Economic Budget for Switchgrass – Fall

Activity/Year	1	2	3	4	5	6	7	8	9	10	TOTAL
Variable Costs											
Seed	\$/ha 70.00	0.00	0.00	0.00	0.00	0.00	0.00	0.00	0.00	0.00	70.00
Herbicide	\$/ha 56.38	0.00	0.00	0.00	0.00	0.00	0.00	0.00	0.00	0.00	0.00
Fertilizers	\$/ha 0.00	72.00	72.00	72.00	72.00	72.00	72.00	72.00	72.00	72.00	648.00
Plowing	\$/ha 17.22	0.00	0.00	0.00	0.00	0.00	0.00	0.00	0.00	0.00	17.22
Discing	\$/ha 0.00	0.00	0.00	0.00	0.00	0.00	0.00	0.00	0.00	0.00	0.00
Harrowing	\$/ha 8.66	0.00	0.00	0.00	0.00	0.00	0.00	0.00	0.00	0.00	8.66
Planting	\$/ha 5.85	0.00	0.00	0.00	0.00	0.00	0.00	0.00	0.00	0.00	5.85
Spraying	\$/ha 6.82	0.00	0.00	0.00	0.00	0.00	0.00	0.00	0.00	0.00	0.00
Fertilizer Application	\$/ha 0.00	2.91	2.91	2.91	2.91	2.91	2.91	2.91	2.91	2.91	26.19
Mowing	\$/ha 5.79	5.79	5.79	5.79	5.79	5.79	5.79	5.79	5.79	5.79	57.90
Baling	\$/ha 19.37	19.37	19.37	19.37	19.37	19.37	19.37	19.37	19.37	19.37	193.70
Twine	\$/ha 3.68	8.40	10.50	10.50	10.50	10.50	10.50	10.50	10.50	10.50	96.08
On-Farm Transport	\$/ha 2.25	2.25	2.25	2.25	2.25	2.25	2.25	2.25	2.25	2.25	22.45
Operating Interest	\$/ha 4.71	2.66	2.71	2.71	2.71	2.71	2.71	2.71	2.71	2.71	29.04
TOTAL	200.71	113.37	115.52	115.52	115.52	115.52	115.52	115.52	115.52	115.52	1155.20
Discounted PV	191.15	102.83	99.79	95.04	90.52	86.21	82.10	78.19	74.47	70.92	709.20
	971.23										
Labour											
Plowing	\$/ha 8.48	0.00	0.00	0.00	0.00	0.00	0.00	0.00	0.00	0.00	8.48
Discing	\$/ha 0.00	0.00	0.00	0.00	0.00	0.00	0.00	0.00	0.00	0.00	0.00
Harrowing	\$/ha 5.25	0.00	0.00	0.00	0.00	0.00	0.00	0.00	0.00	0.00	5.25
Planting	\$/ha 5.36	0.00	0.00	0.00	0.00	0.00	0.00	0.00	0.00	0.00	5.36
Spraying	\$/ha 4.57	0.00	0.00	0.00	0.00	0.00	0.00	0.00	0.00	0.00	0.00
Fertilizer Application	\$/ha 0.00	3.03	3.03	3.03	3.03	3.03	3.03	3.03	3.03	3.03	27.27
Mowing	\$/ha 3.28	3.28	3.28	3.28	3.28	3.28	3.28	3.28	3.28	3.28	32.83
Baling	\$/ha 6.00	6.00	6.00	6.00	6.00	6.00	6.00	6.00	6.00	6.00	60.00
On-Farm Transport	\$/ha 6.00	6.00	6.00	6.00	6.00	6.00	6.00	6.00	6.00	6.00	60.00
TOTAL	38.94	18.31	18.31	18.31	18.31	18.31	18.31	18.31	18.31	18.31	183.10
Discounted PV	37.06	16.61	15.62	15.07	14.35	13.67	13.02	12.40	11.81	11.24	112.40
	161.05										
Fixed Costs											
Plowing	\$/ha 22.24	0.00	0.00	0.00	0.00	0.00	0.00	0.00	0.00	0.00	22.24
Discing	\$/ha 0.00	0.00	0.00	0.00	0.00	0.00	0.00	0.00	0.00	0.00	0.00
Harrowing	\$/ha 9.29	0.00	0.00	0.00	0.00	0.00	0.00	0.00	0.00	0.00	9.29
Planting	\$/ha 8.49	0.00	0.00	0.00	0.00	0.00	0.00	0.00	0.00	0.00	8.49
Spraying	\$/ha 10.53	0.00	0.00	0.00	0.00	0.00	0.00	0.00	0.00	0.00	0.00
Fertilizer Application	\$/ha 0.00	4.01	4.01	4.01	4.01	4.01	4.01	4.01	4.01	4.01	36.13
Mowing	\$/ha 6.02	28.12	28.12	28.12	28.12	28.12	28.12	28.12	28.12	28.12	281.22
Baling	\$/ha 6.71	6.71	6.71	6.71	6.71	6.71	6.71	6.71	6.71	6.71	67.10
On-Farm Transport	\$/ha 6.71	6.71	6.71	6.71	6.71	6.71	6.71	6.71	6.71	6.71	67.10
TOTAL	91.40	44.87	44.87	44.87	44.87	44.87	44.87	44.87	44.87	44.87	448.70
Discounted PV	87.05	40.70	38.76	36.92	35.16	33.48	31.89	30.37	28.92	27.55	275.50
	390.80										
Off-farm Transport (custom)	\$/ha 46.61	106.53	133.16	133.16	133.16	133.16	133.16	133.16	133.16	133.16	1,218.41
Land rent	\$/ha 125.00	125.00	125.00	125.00	125.00	125.00	125.00	125.00	125.00	125.00	1,250.00
GRAND TOTAL	502.66	408.09	436.87	436.87	436.87	436.87	436.87	436.87	436.87	436.87	4368.70
Discounted Cost	\$/ha 478.72	370.15	377.38	359.41	342.30	326.00	310.47	295.69	281.61	268.20	2682.00
Total Present Value	\$3,410										
Yield	odMg 3.68	8.40	10.50	10.50	10.50	10.50	10.50	10.50	10.50	10.50	105.00
Discounted Yield	odMg 3.50	7.62	9.07	8.64	8.23	7.84	7.46	7.11	6.77	6.45	64.50
Total Discounted Yield	odMg 72.67										
Full-Cost	COST/ODMG 46.92										

Table A6.3: Energy Budget for Switchgrass - Fall

Activity/Year	1	2	3	4	5	6	7	8	9	10	TOTAL
Seed	0.43	0.00	0.00	0.00	0.00	0.00	0.00	0.00	0.00	0.00	0.43
Herbicide	0.78	0.00	0.00	0.00	0.00	0.00	0.00	0.00	0.00	0.00	0.78
Fertilizers	0.00	4.39	4.39	4.39	4.39	4.39	4.39	4.39	4.39	4.39	39.48
Plowing	0.79	0.00	0.00	0.00	0.00	0.00	0.00	0.00	0.00	0.00	0.79
Discing	0.00	0.00	0.00	0.00	0.00	0.00	0.00	0.00	0.00	0.00	0.00
Harrowing	0.69	0.00	0.00	0.00	0.00	0.00	0.00	0.00	0.00	0.00	0.69
Planting	0.15	0.00	0.00	0.00	0.00	0.00	0.00	0.00	0.00	0.00	0.15
Spraying	0.12	0.00	0.00	0.00	0.00	0.00	0.00	0.00	0.00	0.00	0.12
Fertilizer Application	0.00	0.06	0.06	0.06	0.06	0.06	0.06	0.06	0.06	0.06	0.56
Mowing	0.25	0.25	0.25	0.25	0.25	0.25	0.25	0.25	0.25	0.25	2.49
Baling	1.41	1.41	1.41	1.41	1.41	1.41	1.41	1.41	1.41	1.41	14.13
On-Farm Transport	0.10	0.10	0.10	0.10	0.10	0.10	0.10	0.10	0.10	0.10	0.98
TOTAL	4.72	6.21	6.21	6.21	6.21	6.21	6.21	6.21	6.21	6.21	6.21
TOTAL OVER 10 YEARS:	60.60										
AVERAGE:	6.06										
Off-farm Transport	0.64	1.46	1.82	1.82	1.82	1.82	1.82	1.82	1.82	1.82	16.65
TOTAL OVER 10 YEARS:	16.65										
AVERAGE:	1.67										
GRAND TOTAL	5.36	7.67	8.03	8.03	8.03	8.03	8.03	8.03	8.03	8.03	8.03
TOTAL OVER 10 YEARS:	77.25										
AVERAGE:	7.73										
ENERGY RATIO:											
TOTAL HARVESTABLE ENERGY	GJ	1,681.31									
TOTAL ENERGY USED	GJ	77.25									
RATIO		22									

Table A6.4: Carbon Budget for Switchgrass – Fall

Activity/Year	1	2	3	4	5	6	7	8	9	10	TOTAL
Variable Costs:											
Seed	8.78	0.00	0.00	0.00	0.00	0.00	0.00	0.00	0.00	0.00	8.78
Herbicides	20.12	0.00	0.00	0.00	0.00	0.00	0.00	0.00	0.00	0.00	0.00
Fertilizers	0.00	78.33	78.33	78.33	78.33	78.33	78.33	78.33	78.33	78.33	704.94
Plowing	15.27	0.00	0.00	0.00	0.00	0.00	0.00	0.00	0.00	0.00	15.27
Discing	0.00	0.00	0.00	0.00	0.00	0.00	0.00	0.00	0.00	0.00	0.00
Harrowing	13.38	0.00	0.00	0.00	0.00	0.00	0.00	0.00	0.00	0.00	13.38
Planting	2.92	0.00	0.00	0.00	0.00	0.00	0.00	0.00	0.00	0.00	2.92
Spraying	2.23	0.00	0.00	0.00	0.00	0.00	0.00	0.00	0.00	0.00	0.00
Fertilizer Application	0.00	1.20	1.20	1.20	1.20	1.20	1.20	1.20	1.20	1.20	10.81
Mowing	4.80	4.80	4.80	4.80	4.80	4.80	4.80	4.80	4.80	4.80	48.03
Baling	27.25	27.25	27.25	27.25	27.25	27.25	27.25	27.25	27.25	27.25	272.51
On-Farm Transport	1.89	1.89	1.89	1.89	1.89	1.89	1.89	1.89	1.89	1.89	18.87
TOTAL	96.63	113.47	113.47	113.47	113.47	113.47	113.47	113.47	113.47	113.47	113.47
TOTAL OVER 10 YEARS:	1,117.84										
AVERAGE:	111.78										

NOTES: emissions from equipment manufacture not included

Off-farm Transport (custom)	12.28	28.07	35.08	35.08	35.08	35.08	35.08	35.08	35.08	35.08	321.02
TOTAL OVER 10 YEARS:	321.02										
AVERAGE:	32.10										

NOTES: emissions from equipment manufacture not included

GRAND TOTAL	108.91	141.53	148.55	148.55	148.55	148.55	148.55	148.55	148.55	148.55	148.55
TOTAL OVER 10 YEARS:	1,438.86										
AVERAGE:	143.89										

Carbon Requirement: 0.86

Table A6.5: Simulation Results for Switchgrass - Fall

* Base Case Values

	Land Rent = 125 Annual Inc. in C = 500														
	Yield=8	9	10.5*	12	13	Rent=75	100	125	150	175	Yield=10.5 Land Rent=125				
Table 1: Economics											Inc=250	500	750	1000	
Cost/odMg:	Full-Cost	57.30	52.46	46.92	42.77	40.53	41.61	44.26	46.92	49.58	52.23	46.92	46.92	46.92	46.92
	Variable Cost	17.22	15.42	13.36	11.82	10.99	13.36	13.36	13.36	13.36	13.36	13.36	13.36	13.36	13.36
	Labour	2.91	2.59	2.22	1.94	1.79	2.22	2.22	2.22	2.22	2.22	2.22	2.22	2.22	2.22
	V.C.+ Labour	20.13	18.01	15.58	13.76	12.78	15.58	15.58	15.58	15.58	15.58	15.58	15.58	15.58	15.58
	V.C.+ Off Farm Trans.	29.90	28.10	26.05	24.50	23.67	26.05	26.05	26.05	26.05	26.05	26.05	26.05	26.05	26.05
	V.C.+ Rent	34.65	30.92	26.65	23.44	21.72	21.33	23.99	26.65	29.30	31.96	31.96	26.65	26.65	26.65
	V.C.+ Off Farm Trans. + Rent	47.33	43.60	39.33	36.12	34.40	34.02	36.67	39.33	41.98	44.64	39.33	39.33	39.33	39.33
Fixed Cost	7.06	6.27	5.38	4.71	4.34	5.38	5.38	5.38	5.38	5.38	5.38	5.38	5.38	5.38	
Table 2: Inputs															
T-Bill rate	0.0486	0.0486	0.0486	0.0486	0.0486	0.0486	0.0486	0.0486	0.0486	0.0486	0.0486	0.0486	0.0486	0.0486	
	0.05	0.05	0.05	0.05	0.05	0.05	0.05	0.05	0.05	0.05	0.05	0.05	0.05	0.05	
	8	9	10.5	12	13	10.5	10.5	10.5	10.5	10.5	10.5	10.5	10.5	10.5	
	125	125	125	125	125	75	100	125	150	175	125	125	125	125	
Table 3: Energy Budget															
Energy Ratio:	Total Harvestable Energy (GJ)	1,281.00	1,441.13	1,681.31	1,921.50	2,081.63	1,681.31	1,681.31	1,681.31	1,681.31	1,681.31	1,681.31	1,681.31	1,681.31	
	Total Energy Used (GJ)	73.29	74.88	77.25	79.63	81.22	77.25	77.25	77.25	77.25	77.25	77.25	77.25	77.25	
	Ratio	17.48	19.25	21.76	24.13	25.63	21.76	21.76	21.76	21.76	21.76	21.76	21.76	21.76	
Table 4: Carbon Requirements															
Straight Ratio	Fossil Carbon Required	1,362.42	1,393.00	1,438.86	1,484.72	1,515.29	1,438.86	1,438.86	1,438.86	1,438.86	1,438.86	1,438.86	1,438.86	1,438.86	
	Biomass Energy Produced:	1,281.00	1,441.13	1,681.31	1,921.50	2,081.63	1,681.31	1,681.31	1,681.31	1,681.31	1,681.31	1,681.31	1,681.31	1,681.31	
	Carbon Requirement	1.06	0.97	0.86	0.77	0.73	0.86	0.86	0.86	0.86	0.86	0.86	0.86	0.86	
Ratio Adjusted for Soil Carbon Accumulation	Annual Increment in Soil Carbon	500	500	500	500	500	500	500	500	500	500	500	500	500	
	Net Carbon Required	-3,638	-3,607	-3,561	-3,515	-3,485	-3,561	-3,561	-3,561	-3,561	-3,561	-3,561	-3,561	-3,561	
	Carbon Requirement	-2.84	-2.50	-2.12	-1.83	-1.67	-2.12	-2.12	-2.12	-2.12	-2.12	-2.12	-2.12	-2.12	
Ratio Adjusted for Soil Carbon Accumulation and Changes in Landscape:	Net Carbon Required	-5.935	-5.904	-5.858	-5.812	-5.782	-5.858	-5.858	-5.858	-5.858	-5.858	-5.858	-5.858	-5.858	
	Carbon Requirement	-4.63	-4.10	-3.48	-3.02	-2.78	-3.48	-3.48	-3.48	-3.48	-3.48	-3.48	-3.48	-3.48	
ABOVE GROUND CARBON	Com	7166	7166	7166	7166	7166	7166	7166	7166	7166	7166	7166	7166	7166	
	Switchgrass	6974	6974	6974	6974	6974	6974	6974	6974	6974	6974	6974	6974	6974	
	Difference	-192	-192	-192	-192	-192	-192	-192	-192	-192	-192	-192	-192	-192	
BELOW GROUND CARBON	Com	660	660	660	660	660	660	660	660	660	660	660	660	660	
	Switchgrass	3149	3149	3149	3149	3149	3149	3149	3149	3149	3149	3149	3149	3149	
	Difference	2489	2489	2489	2489	2489	2489	2489	2489	2489	2489	2489	2489	2489	